

From the library of: Diamond Needle Co.

Ref. No.	Parts No.	Description	品名	Amt. Req.
1	26044	Upper Knife Driving Connecting Rod	上メスロッド	1
2	5070	Screw for 26044	上メスロッド止ネジ	2
3	32921	Connecting Rod Pin	上メスロッドピン	1
4	9508	Screw for 32921	上メスロッドピン止ネジ	1
5	26263	Upper Knife Driving Lever	上メス軸腕	1
6	520	Washer for 26263	ワッシャ	1
7	5520	Screw for 26263	上メス軸腕止ネジ	1
8	20487	Thrust Washer	上メス軸スラストリング	1
9	32920	Upper Knife Driving Shaft Collar (Left)	上メス軸カラー (左)	1
10	5550	Screw for 32920	上メス軸カラー (左) 止ネジ	1
11	639	Seal Plug for 26066	詰栓	2
12	26066	Upper Knife Driving Shaft	上メス軸	1
13	20490	Upper Knife Holder Positioner	上メスホルダ止メ	1
14	24081	Upper Knife Holder (Flat Type)	上メスホルダ (平)	1
15	7405	Screw for 24081	上メスホルダ (平) 止ネジ	1
16	20496	Upper Knife (Flat Type)	上メス (平)	1
17	532	Washer for 20496	ワッシャ	1
18	4106	Screw for 20496	上メス (平) 止ネジ	1
19	28086	Lower Knife Clamp	下メス押エ	1
20	4317	Screw for 28086	下メス押エ止ネジ	2
21	22195	Lower Knife	下メス	1
22	28085	Lower Knife Holder	下メス台	1
23	3655	Screw for 28085	下メス台止ネジ	1
24	32756	Lower Knife Holder Spring	下メスバネ	1
25	35955	Lower Knife Holder Locking Plate	下メス台回り止メ	1
26	5036	Screw for 35955	下メス台回り止メ止ネジ	2
27	35956	Lower Knife Holder Spring Stopper	下メス台バネストッパ	1
28	35989	Latch Spring Catcher	筒蓋バネ掛ケ	1

From the library of: Diamond Needle Corp

Ref. No.	Parts No.	Description	品名	Amt. Req.
1	4209	Adjusting Screw for 24138	押エバネ調節ネジ	1
2	24138	Presser Spring	押エバネ	1
3	24139	Presser Arm Positioning Guide Pin	押工腕案内ピン	1
4	3637	Screw for 24139, 24141, 26141	止ネジ	3
5	24023	Presser Spring Adjusting Bar	押エバネ調節棒	1
6	9503	Screw for 24023	押エバネ調節棒止ネジ	2
7	24024	Presser Spring Adjusting Bar Stopper	押エバネ調節棒ストッパ	1
8	1228	Screw for 24024	押エバネ調節棒ストッパ止ネジ	1
9	26064	Presser Arm Positioning Guide	押工腕案内	1
10	24021	Presser Foot Pin	押エピン	1
11	3436	Stooper Screw for 24023	押エバネ調節棒ストッパネジ	1
12	26060	Presser Spring Adjusting Bar Support	押エバネ調節棒サポート	1
13	1223	Screw for 26060	押エバネ調節棒サポート止ネジ	2
14	322	Lock Nut for 9533	ロックナット	1
15	9533	Stopper Screw for 24023	押エバネ調節棒ストッパネジ	1
16	22257	Presser Arm Stopper	押工腕ストッパ	1
17	1202	Screw for 22257	押工腕ストッパ	1
18	20293	Presser Foot Release Lever Spring	押工腕ストッパ止ネジ	1
19	6094	Screw for 20293	手揚ゲバネ	1
20	24080	Presser Foot Release Lever	手揚ゲバネ掛ケネジ	1
21	4107	Screw for 24080	手揚ゲ	1
22	26058	Presser Foot Lifter Lever	手揚ゲ止ネジ	1
23	26065	Presser Foot Lifter Lever Spring	押工揚ゲレバー	1
24	4103	Screw for 26058	押工揚ゲレバーバネ	1
25			押工揚ゲレバー止ネジ	1
26	26059	Presser Foot Lifter Lever Link	押工揚ゲレバーリンク	1
27	26057	Intermediate Lever Spring	押工揚ゲ軸バネ	1
28	26056	Intermediate Lever	押工揚ゲ軸レバー	1
29	5550	Screw for 26056	押工揚ゲ軸レバー止ネジ	1
30	4352	Stopper Screw for 26056	押工揚ゲ軸レバーストッパネジ	1
31	335	Lock Nut for 4352	ロックナット	1
32	30228	Presser Foot Lifter Lever Shaft Collar	押工揚ゲ軸カラー	2
33	3638	Screw for 30228	押工揚ゲ軸カラー止ネジ	4
34	26054	Presser Foot Lifter Lever Shaft Bushing	押工揚ゲ軸ブッシュ	1
35	3635	Screw for 26054	押工揚ゲ軸ブッシュ止ネジ	1
36	26062	Presser Arm, Complete Set	押工腕(組)	1
37	26050	Presser Arm Hinge	押工腕ヒンジ	1
38	34293	Retaining Ring	ストップリング	1
39	24141	Presser Arm Hinge Pin	押工腕ヒンジピン	1
40	26049	Presser Arm	押工腕	1
41	26053	Presser Foot Lifter Lever Shaft	押工揚ゲ軸	1
42	26432	Spacer Holding Spring	スぺーサ保持バネ	1
43	5044	Screw for 26432	スぺーサ保持バネ止ネジ	2
44	26051	Presser Foot Lifter Spacer	押工揚ゲスぺーサ	1
45	4141	Screw for 26051, 26142	止ネジ	3
46	20271	Thread Chain Cutting Knife	チェーンカッタ	1
47	4097	Screw for 20271	チェーンカッタ止ネジ	1
48-1	28104	Presser Foot, Complete Set (Y5)	押工(組)(Y5)	1
48-2	28105	Presser Foot, Complete Set (Y6)	"(Y6)	1
49	28106	Presser Foot Hinge	押工ヒンジ	1
50	4351	Screw for 28106	押工ヒンジ止ネジ	1
51	27023	Presser Foot Spring	押エバネ	1
52-1	28102	Presser Foot (Y5)	押工(Y5)	1
52-2	28103	Presser Foot (Y6)	"(Y6)	1
53	26140	Presser Foot Hinge Pin	押工ヒンジピン	1
54	26142	Presser Foot Chain Shield	空糸押工	1
55	4237	Screw for 26142	空糸押工止ネジ	1
56	26039	Presser Foot Lifter Lever Stopper	押工揚ゲレバーストッパ	1
57	5118	Screw for 26039	押工揚ゲレバーストッパ止ネジ	2

From the library of: Diamond Needle Corp

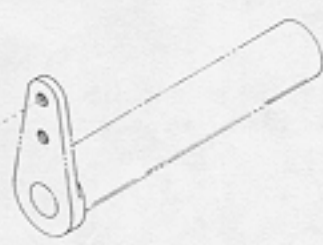
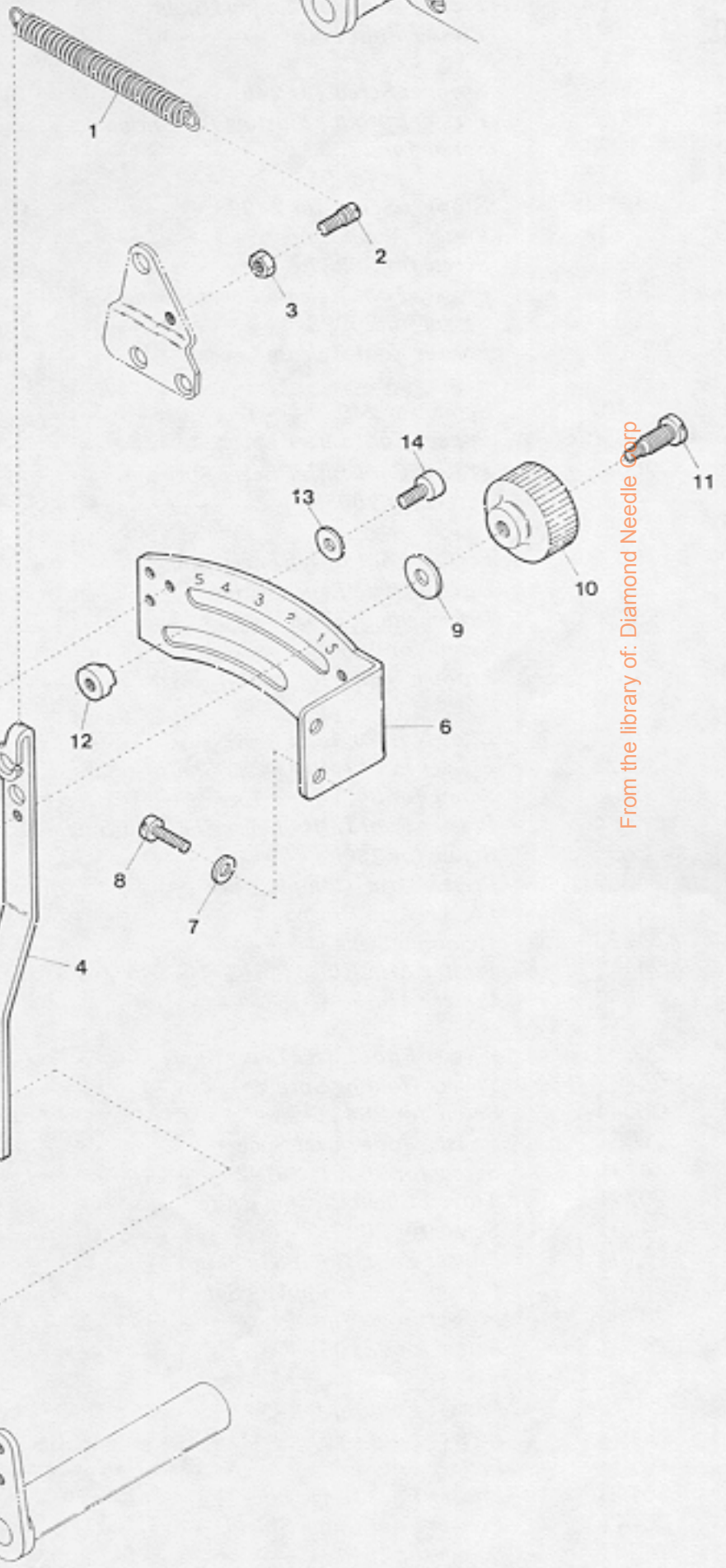
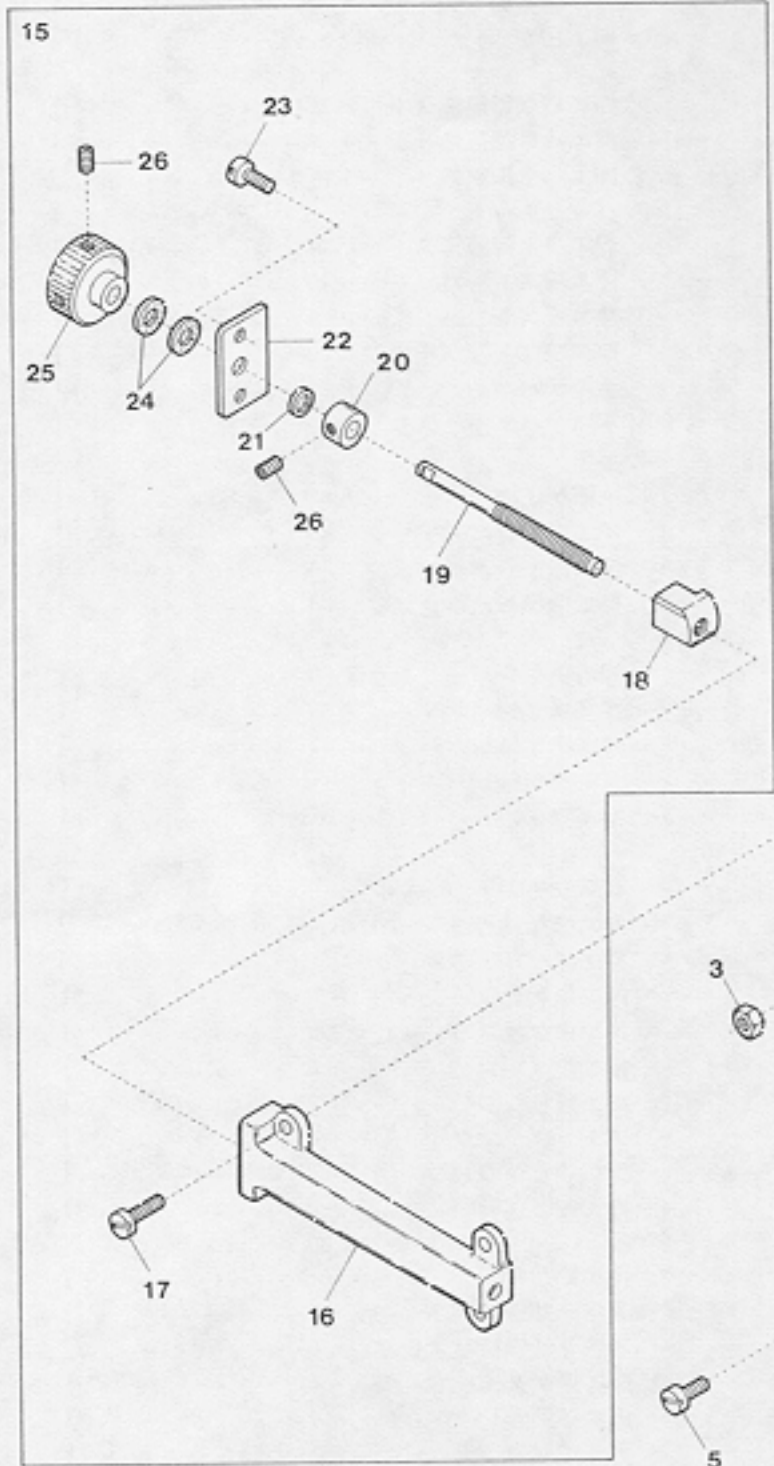
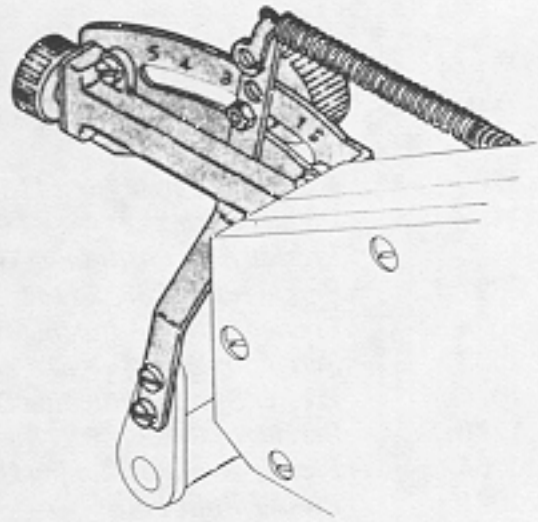

22

From the library of: Diamond Needle Corp

<u>Ref. No.</u>	<u>Parts No.</u>	<u>Description</u>	<u>品名</u>	<u>Amt. Req.</u>
1	26123	Top Feed Differential Lever Spring	差動レバーバネ	1
2	4446	Screw for 26123	バネ掛けネジ	1
3	334	Lock Nut for 4446, 4094	ロックナット	2
4	26112	Top Feed Differential Lever	上送り差動レバー	1
5	1202	Screw for 26112	上送り差動レバー止ネジ	2
6	26425	Top Feed Differential Feeding Graduations	上送り目盛板	1
7	538	Washer for 26425	ワッシャ	2
8	9150	Screw for 26425	上送り目盛板止ネジ	2
9	613	Washer for 26112	ワッシャ	1
10	242	Adjusting Nut for 26112	調節ナット	1
11	4094	Adjusting Screw for 26112	調節ネジ	1
12	20420	Top Feed Differential Lever Stopper	上送り差動レバーストッパ	1
13	186	Washer for 20420	ワッシャ	1
14	5038	Screw for 20420	差動レバーストッパ止ネジ	1
15	26434	Top Feed Differential Lever Adjusting Box, Complete Set	差動レバー調節台(組)	1
16	26427	Top Feed Differential Lever Adjusting Box	差動レバー調節台	1
17	4440	Screw for 26427	差動レバー調節台止ネジ	1
18	26430	Top Feed Differential Lever Stopper	差動レバーストッパ	3
19	26428	Top Feed Differential Lever Adjusting Screw	差動レバー調節ネジ	1
20	26438	Collar for 26428	差動レバー調節ネジカラー	1
21	396	Rubber Cushion for 26438	ラバークッション	1
22	26429	Supporting Plate for 26428	差動レバー調節ネジ支え板	1
23	4351	Screw for 26429	差動レバー調節ネジ支え板止ネジ	2
24	280	Rubber Cushion for 26431	ラバークッション	2
25	26431	Adjusting Knob	ストッパ調節ツマミ	1
26	3637	Screw for 26431, 26438	止ネジ	3

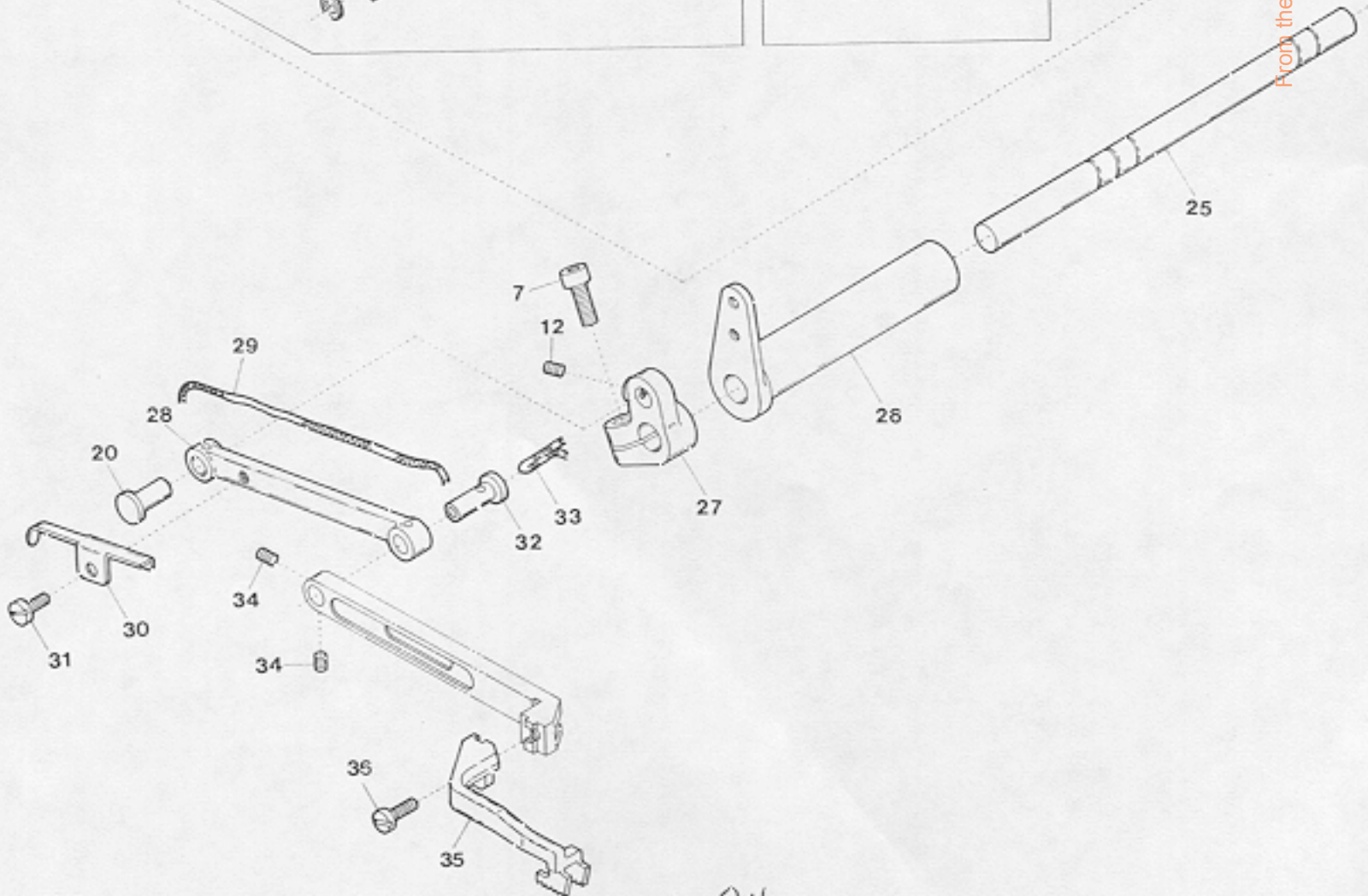
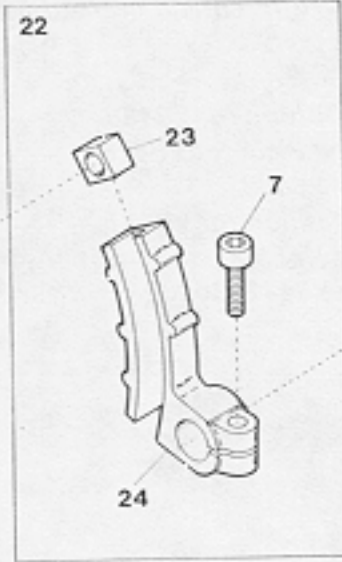
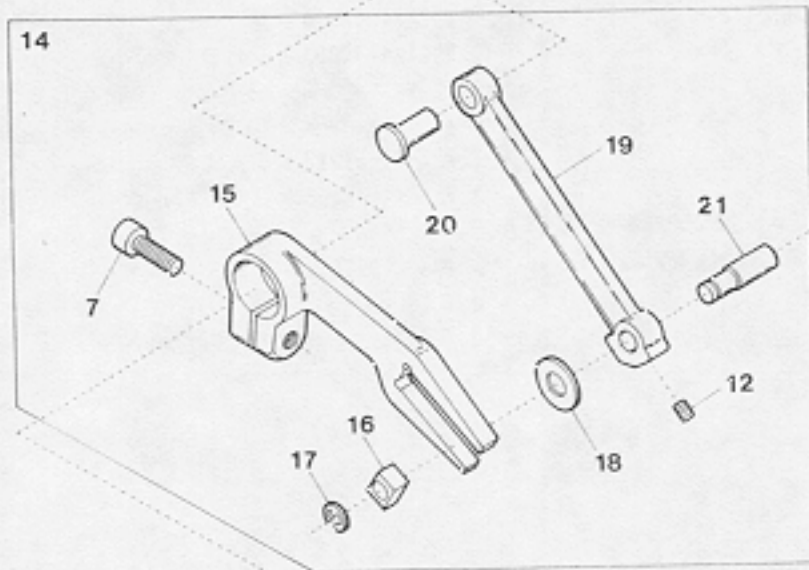
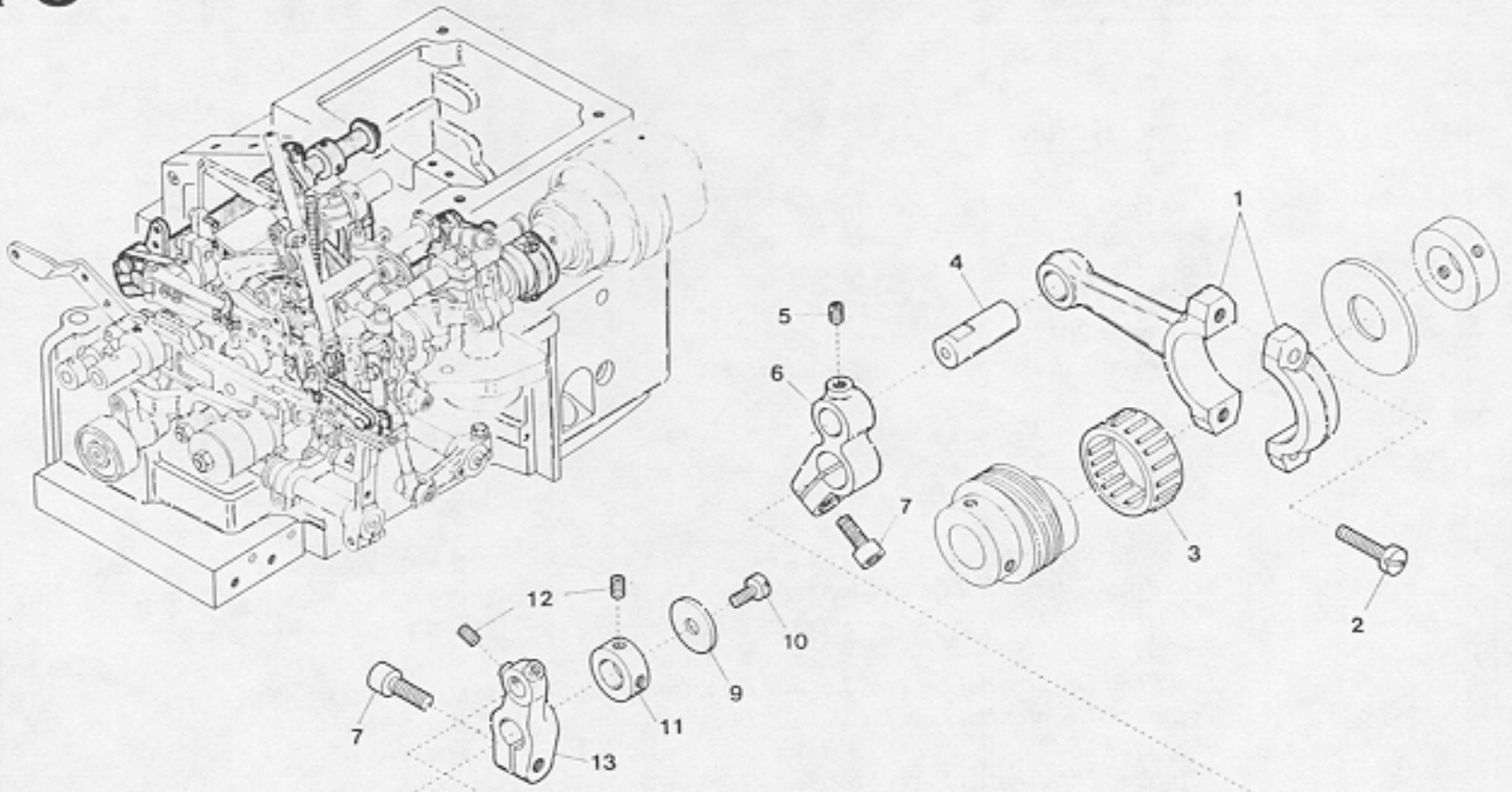

From the library of: Diamond Needle Corp

Ref. No.	Parts No.	Description	品名	Amt. Req.
1	26401	Top Feed Dog Driving Connecting Rod	上送りロッド	1
2	5071	Screw for 26401	上送りロッド止ネジ	2
3	94564	Roller Bearing for 26401	ニードルベアリング	1
4	26402	Top Feed Dog Driving Connecting Rod Pin	上送りロッドピン	1
5	3635	Screw for 26402	上送りロッドピン止ネジ	1
6	24104	Top Feed Shaft Lever	上送り軸腕	1
7	5520	Screw for 24104, 26414, 26415, 26408, 26416	止ネジ	5
8	26406	Top Feed Shaft (Left)	上送り軸(左)	1
9	26091	Top Feed Shaft Thrust Washer	スラストプレート	1
10	4406	Screw for 26091	スラストプレート止ネジ	1
11	30228	Top Feed Shaft (Upper) Collar	上送り軸(上)カラー	1
12	3638	Screw for 30228, 26104, 26412	止ネジ	7
13	26414	Top Feed Shaft Lever (Right)	上送り軸腕(右)	1
14	26433	Top Feed Rocker, Complete Set (2)	上送り腕(組2)	1
15	26415	Slide Pin Adjusting Lever	スライダ調整レバー	1
16	26099	Top Feed Guide Block	上送り前後駒	1
17	33024	Retaining Ring	ストップリング	1
18	26413	Spacer	スペーサ	1
19	26412	Top Feed Shaft Lever Link (Right)	上送り軸腕リンク(右)	1
20	26104	Pin for 26412, 26101	上送り軸腕リンクピン	2
21	26411	Top Feed Retaining Slider Pin	スライダピン	1
22	26410	Top Feed Rocker, Complete Set (1)	上送り腕(組1)	1
23	26409	Top Feed Regulating Slider	スライダ	1
24	26408	Top Feed Rocker	上送り腕	1
25	26088	Top Feed Shaft (Upper)	上送り軸(上)	1
26	26098	Slider Pin Adjusting Lever Shaft	スライダ調整レバー軸	1
27	26416	Top Feed Shaft Lever (Left)	上送り軸腕(左)	1
28	26101	Top Feed Shaft Lever Link (Left)	上送り軸腕リンク(左)	1
29	1113	Oil Wick for 26101	油芯	1
30	26029	Oil Wick Stay	油芯支エ	1
31	1230	Screw for 26029	油芯支エ止ネジ	1
32	26418	Top Feed Dog Bar Connecting Pin	上送り台ピン	1
33	1117	Oil Wick for 26418	油芯(糸)	1
34	3637	Screw for 26418	上送り台ピン止ネジ	2
35	26513	Top Feed Dog	上送り	1
36	7609	Screw for 26513	上送り止ネジ	1

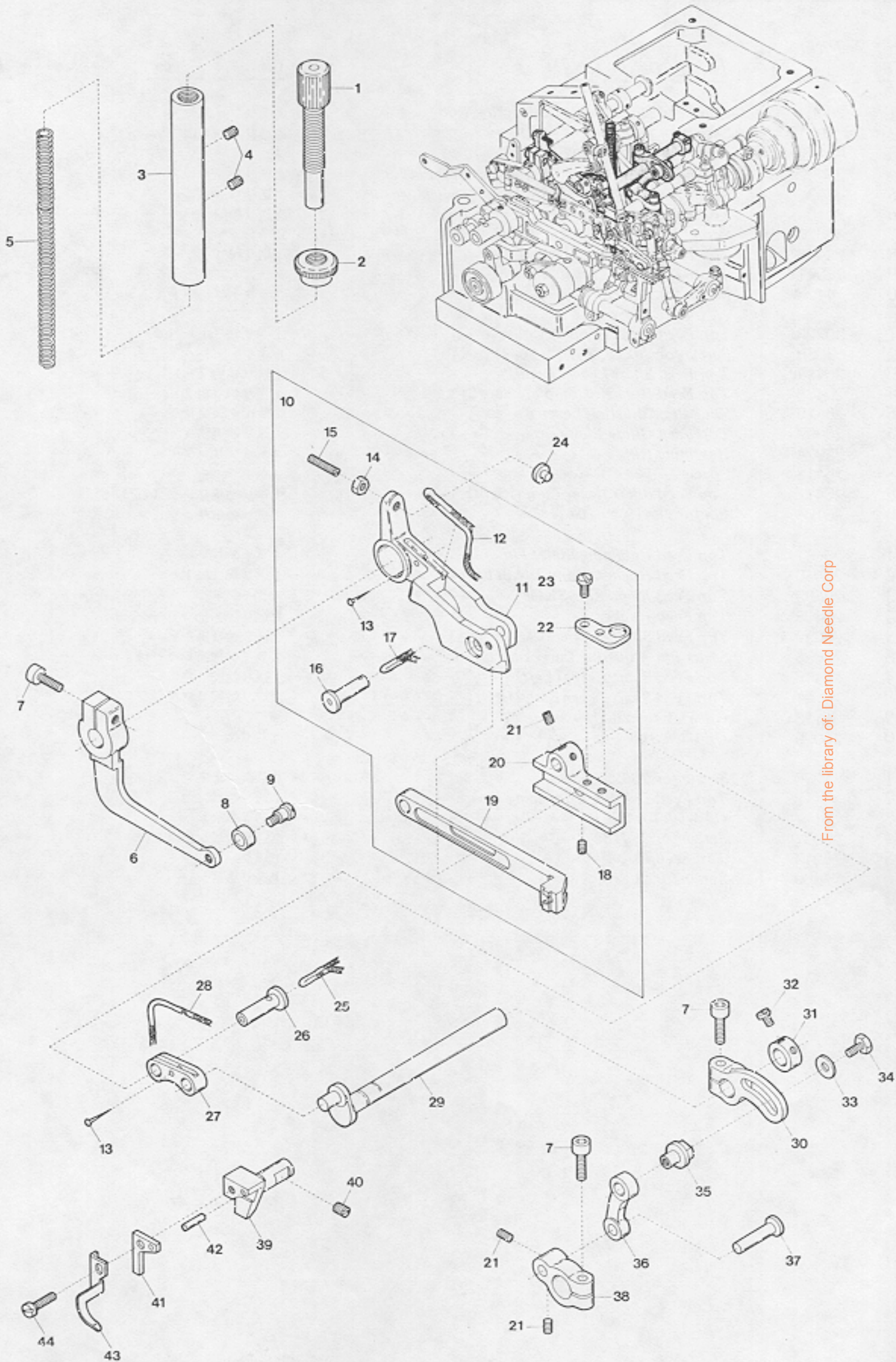

From the library of: Diamond Needle Corp

Ref. No.	Parts No.	Description	品名	Amt. Req.
1	4272	Adjusting Screw for 26118	調節ネジ	1
2	449	Lock Nut for 4272	ロックナット	1
3	26117	Top feed Dog Press Spring Adjusting Bar	調節棒	1
4	9503	Screw for 26117	調節棒止ネジ	2
5	26118	Top Feed Dog Press Spring	上送り押エバネ	1
6	26119	Top Feed Dog Lifting Lever	リフトレバー	1
7	5550	Screw for 26119, 26074, 26077	止ネジ	3
8	26120	Lifting Lever Roller	リフトレバーコロ	1
9	4270	Screw for 26120	リフトレバーコロ止ネジ	1
10	26424	Top Feed Dog Bar, Complete Set	上送り台(組)	1
11	26107	Top Feed Dog Press Arm	上送り押エ腕	1
12	1112	Oil Wick for 26107	油芯	1
13	755	Pin for 1112, 1110	油芯止メピン	2
14	334	Lock Nut for 1435	ロックナット	1
15	1435	Adjusting Screw for 26107	上送り押エ腕調節ネジ	1
16	26109	Pin for 26107	上送り押エ腕ピン	1
17	1116	Oil Wick for 26109	油芯(糸糸)	1
18	9526	Screw for 26109	上送り押エ腕ピン止ネジ	1
19	26417	Top Feed Dog Bar	上送り台	1
20	26126	Top Feed Dog Bar Guide	上送り台ガイド	1
21	3637	Screw for 26073, 26078	止ネジ	4
22	26125	Press Spring Holder	バネ受け	1
23	5065	Screw for 26125	バネ受け止ネジ	2
24	23234	Positioning Pin for 26107	上送り押エ腕位置決メピン	1
25	1115	Oil Wick for 26073	油芯(糸糸)	1
26	26073	Pil for 26072	上送り上下軸リンクピン	1
27	26072	Top Feed Vertical Motion Shaft Link	上送り上下軸リンク	1
28	1110	Oil Wick for 26072	油芯	1
29	26068	Top Feed Vertical Motion Shaft	上送り上下軸	1
30	26074	Top Feed Vertical Motion Adjusting Lever	上送り上下調節レバー	1
31	30228	Top Feed Vertical Motion Shaft Collar	上送り上下軸カラー	1
32	9604	Screw for 30228	上送り上下軸カラー止ネジ	2
33	533	Washer for 26075	ワッシャ	1
34	4106	Screw for 26075	上送り上下調節レバーピン止ネジ	1
35	26075	Pin for 26074	上送り上下調節レバーピン	1
36	26076	Top Feed Vertical Motion Lever Link	上送り上下レバーリンク	1
37	26078	Pin for 26077	上送り上下レバーピン	1
38	26077	Top Feed Vertical Motion Lever	上送り上下レバー	1
39	26122	Top Feed Dog Bar Support (Right)	上送り台サポート(右)	1
40	2022	Screw for 26122	上送り台サポート(右)止ネジ	1
41	26421	Top Feed Dog Bar Support (Left)	上送り台サポート(左)	1
42	687	Pin for 26421	位置決メピン	1
43	26422	Presser Foot Adjusting Plate	押エ前上り板	1
44	4353	Screw for 26421	上送り台サポート(左)止ネジ	1

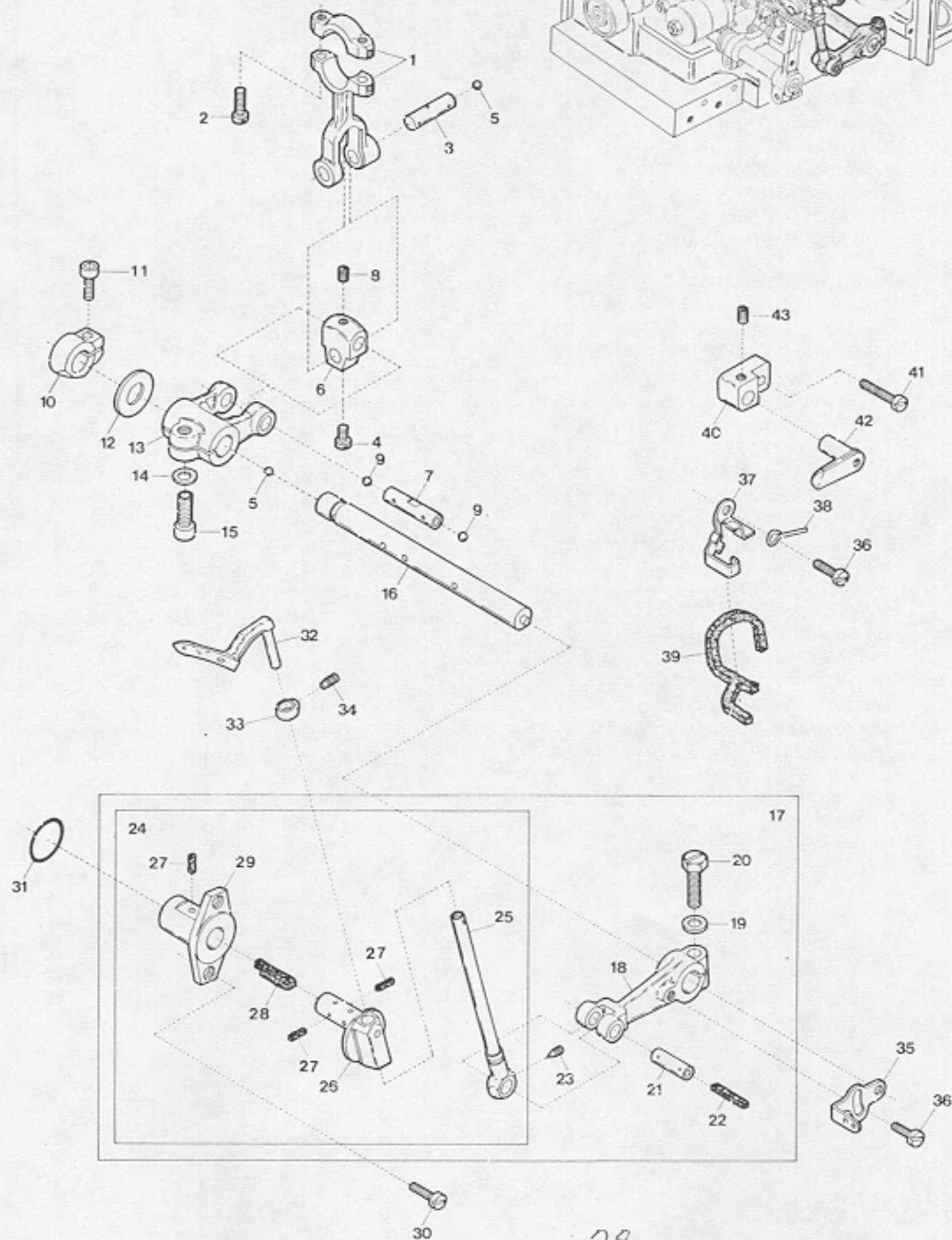
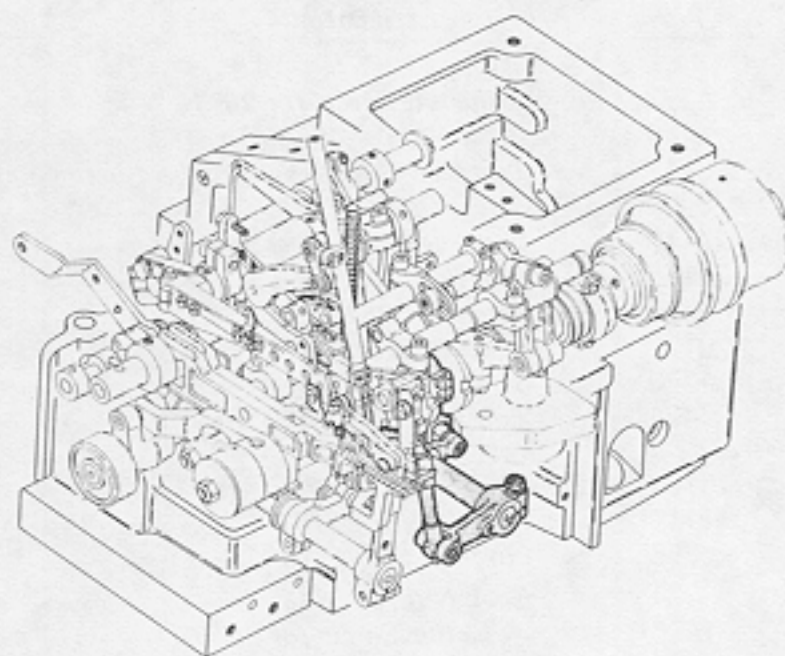

From the library of: Diamond Needle Corp

Ref. No.	Parts No.	Description	品名	Amt. Req.
1	28066	Oil Receiver	油受ケ皿	1
2	4437	Screw for 28066	油受ケ皿止ネジ	1
3	34637	Cloth Plate Eccentric Bushing	クロスプレートエキセンブッシュ	1
4	7650	Screw for 34637	エキセンブッシュ止ネジ	2
5	28006	Cloth Plate Hinge	クロスプレートヒンジ	1
6	5087	Screw for 28006	クロスプレートヒンジ止ネジ	2
7	5089	Screw for 28006	クロスプレートヒンジ止ネジ	1
8	28008	Cloth Plate Hinge Shield	クロスプレートヒンジ油除ケ	1
9	7006	Screw for 28008	クロスプレートヒンジ油除ケ止ネジ	2
10	24197	Machine Frame Stay	フレーム支エ	1
11	4440	Screw for 24197	フレーム支エ止ネジ	2
12	32976	Machine Frame Stay Rubber Cushion	フレーム支エゴム座	1
13	28062	Machine Frame	フレーム	1
14	613	Washer for 20080	ワッシャ	4
15	20080	Oil Reservoir Positioning Bar	油受ケ固定棒	4
16	28041	Oil Reservoir Gasket	油受ケパッキン	1
17	28040	Oil Reservoir	油受ケ	1
18	184	Washer for 28040	ワッシャ	4
19	5108	Screw for 28040	油受ケ止ネジ	4
20	32421	Drain Hole Seal for Inner	Oリング	1
21	5076	Drain Hole Screw for Inner	油受ケ油抜キネジ	1
22	35149	Oil Reservoir Magnet	油受ケマグネット	1
23	35150	Oil Reservoir Magnet Holder	油受ケマグネット押エ	1
24	9150	Screw for 35150	油受ケマグネット押エ止ネジ	1
25	28005	Cloth Plate Stay	クロスプレート支エ板	1
26	5036	Screw for 28005	クロスプレート支エ板止ネジ	1
27	28050	Cloth Plate	クロスプレート	1
28	528	Washer for 28050	ワッシャ	1
29	34505	Cloth Plate Hinge Pin Collar	クロスプレートヒンジピンカラー	1
30	1459	Screw for 34505	ヒンジピンカラー止ネジ	2
31	35972	Cloth Plate Spring Support	クロスプレートバネ取付台	1
32	4358	Screw for 35972	クロスプレートバネ取付台止ネジ	2
33	35971	Cloth Plate Spring	クロスプレートバネ	1
34	4236	Screw for 35971	クロスプレートバネ止ネジ	2
35	334	Stopper Nut for 28050	クロスプレートストップナット	1
36	9106	Stopper Screw for 28050	クロスプレートストップバネジ	1

From the library of: Diamond Needle Corp

Ref. No.	Parts No.	Description	品名	Amt. Req.
1	24191	Upper Looper Driving Lever Connecting Rod	上ルーパロッド	1
2	5070	Screw for 24191	上ルーパロッド止ネジ	2
3	24194	Looper Driving Lever Connecting Rod Pin	上ルーパロッドピン	1
4	4410	Screw for 24194	上ルーパロッドピン止ネジ	1
5	638	Seal Plug for 24194, 24063	詰栓	2
6	24193	Looper Driving Lever Link	ルーパリンク	1
7	24195	Looper Driving Lever Link Pin	ルーパリンクピン	1
8	1457	Screw for 24195	ルーパリンクピン止ネジ	1
9	637	Seal Plug for 24195	詰栓	2
10	26038	Upper Looper Driving Shaft Collar	上ルーパ軸カラー	1
11	5550	Screw for 26038	上ルーパ軸カラー止ネジ	1
12	26037	Driving Shaft Thrust Washer	スラストプレート	1
13	24192	Upper Looper Driving Lever	上ルーパ軸腕	1
14	507	Washer for 24192	ワッシャ	1
15	5108	Screw for 24192	上ルーパ軸腕止ネジ	1
16	24063	Upper Looper Driving Shaft	上ルーパ軸	1
17	26265	Upper Looper Bar Driving Arm, Complete Set	上ルーパ腕 (組)	1
18	22554	Upper Looper Bar Driving Arm	上ルーパ腕	1
19	520	Washer for 22554	ワッシャ	1
20	5522	Screw for 22554	上ルーパ腕止ネジ	1
21	20331	Upper Looper Bar Driving Arm Pin	上ルーパ腕ピン	1
22	278	Oil Wick for 20331	油芯	1
23	3313	Screw for 20331	上ルーパ腕ピン止ネジ	1
24	26264	Upper Looper Bar, Complete Set	ルーパ棒 (組)	1
25	24481	Upper Looper Bar	ルーパ棒	1
26	20320	Upper Looper Bar Guide	ルーパ案内	1
27	171	Oil Wick for 20320, 22854	油芯	1
28	265	Oil Wick for 20320	油芯	1
29	22854	Upper Looper Bar Guide Bushing	ルーパ案内ブッシュ	1
30	9508	Screw for 22854	ルーパ案内ブッシュ止ネジ	2
31	77432	Seal for 22854	Oリング	1
32	21700	Upper Looper	上ルーパ	1
33	21705	Upper Looper Holder Collar	上ルーパ止メカラー	1
34	4144	Screw for 21705	上ルーパ止メカラー止ネジ	1
35	20112	Looper Thread Pull-off	ルーパ糸繰り	1
36	4358	Screw for 20112, 20330	止ネジ	2
37	20330	Looper Bar Oil Wick Holder Plate	ルーパ棒油芯止メ板	1
38	32812	Oiling Felt Retainer	フェルト押エ	1
39	23468	Oil Wick for 24481	油芯	1
40	20322	Looper Bar Guide Holder Bracket	ルーパ案内押エ台	1
41	7311	Screw for 20322	ルーパ案内押エ台止ネジ	1
42	20323	Looper Bar Guide Holder	ルーパ案内押エ	1
43	3638	Screw for 20323	ルーパ案内押エ止ネジ	1

From the library of: Diamond Needle Corp

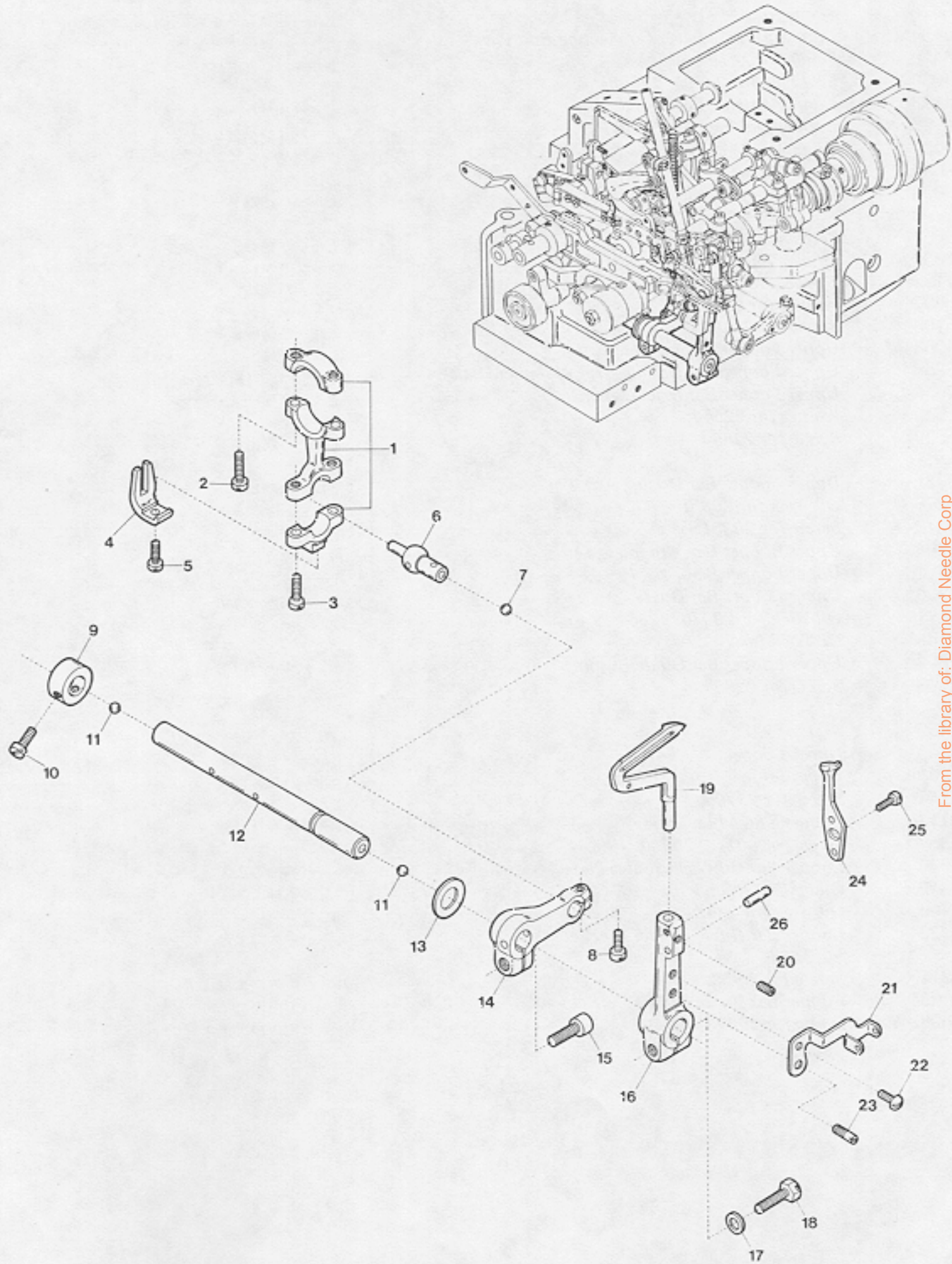

From the library of: Diamond Needle Corp

<u>Ref. No.</u>	<u>Parts No.</u>	<u>Description</u>	<u>品名</u>	<u>Amt. Req.</u>
1	24064	Lower Looper Driving Lever Connecting Rod	下ルーパロッド	1
2	5070	Screw for 24064	下ルーパロッド止ネジ	2
3	8101	Screw for 24064	下ルーパロッド止ネジ	2
4	33057	Bail Joint Guide Fork	振レ止メ	1
5	9853	Screw for 33057	振レ止メ止ネジ	1
6	24065	Ball Stud	下ルーパロッド球	1
7	636	Seal Plug for 24065	詰栓	1
8	4437	Screw for 24065	下ルーパロッド球止ネジ	1
9	30228	Lower Looper Driving Shaft Collar	下ルーパ軸カラー	1
10	9604	Screw for 30228	下ルーパ軸カラー止ネジ	2
11	638	Seal Plug for 24077	詰栓	2
12	24077	Lower Looper Driving Shaft	下ルーパ軸	1
13	24069	Driving Shft Thrust Washer	スラストプレート	1
14	24068	Lower Looper Driving Lever	下ルーパ軸腕	1
15	5108	Screw for 24068	下ルーパ軸腕止ネジ	1
16	21703	Lower Looper Holder Arm	下ルーパ台	1
17	520	Washer for 21703	ワッシャ	1
18	5500	Screw for 21703	下ルーパ台止ネジ	1
19	21701	Lower Looper	下ルーパ	1
20	3638	Screw for 21701	下ルーパ止ネジ	1
21	21717	Looper Thread Pull-off	下ルーパ糸繰り	1
22	9121	Screw for 21717	下ルーパ糸繰り止ネジ	1
23	4130	Guide Screw for 21717	下ルーパ糸繰りガイドネジ	1
24	24169	Needle Guard (Rear)	針受ケ (後)	1
25	5036	Screw for 24169	針受ケ (後) 止ネジ	1
26	688	Positioning Pin for 24169	位置決メピン	1

From the library of: Diamond Needle Corp.

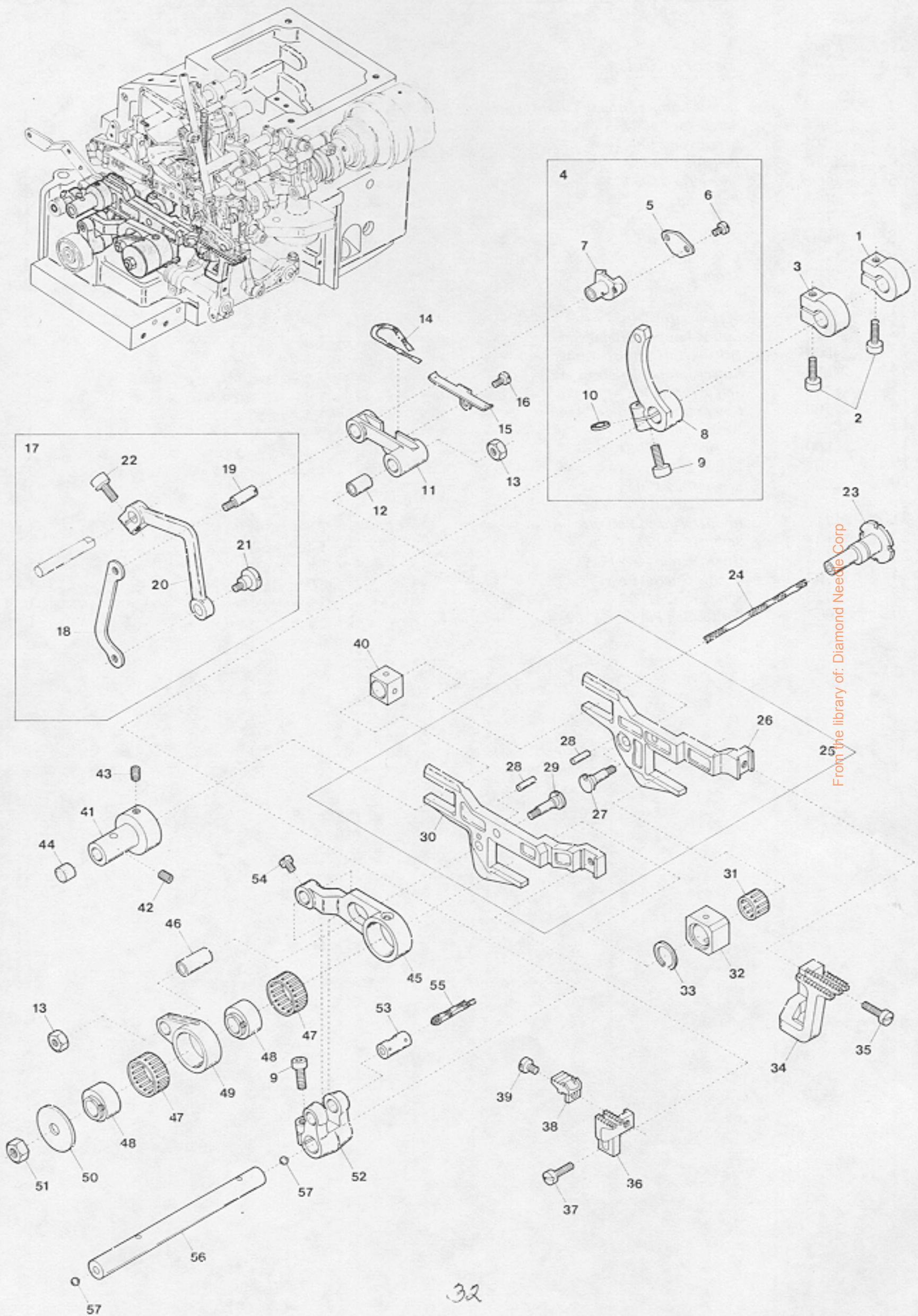

From the library of: Diamond Needle Corp

Ref. No.	Parts No.	Description	品名	Amt. Req.
1	93323	Feed Bar Driving Shaft Collar (Right)	送り軸カラー (右)	1
2	5550	Screw for 93323, 33104	送り軸カラー止ネジ	2
3	33104	Feed Bar Driving Shaft Collar (Left)	送り軸カラー (左)	1
4	28028	Differential Feed Rocker, Complete Set	前送り腕 (組)	1
5	28027	Differential Feed Regulating Slide Pin Cap	スライダキャップ	1
6	9624	Screw for 28027	スライダキャップ止ネジ	2
7	28026	Differential Feed Regulating Slide Pin	スライダ	1
8	28025	Differential Feed Rocker	前送り腕	1
9	5520	Screw for 28025, 33105	止ネジ	2
10	567	Seal for 28025	パッキン	1
11	28022	Differential Feed Bar Driving Connection	前送りリンク	1
12	33098	Feed Bar Driving Connection Bushing	送りリンクブッシュ	1
13	451	Nut for 33098, 34137	ナット	2
14	192	Oil Wick for 28022	油芯	1
15	24184	Oil Wick Holder	前送りリンク油芯押エ	1
16	7616	Screw for 24184	前送りリンク油芯押エ止ネジ	1
17	28031	Differential Feed Control Link, Complete Set	前送り調節リンク (組)	1
18	28029	Differential Feed Control Link	前送り調節リンク	1
19	5512	Screw for 28029	前送り調節リンク止ネジ	1
20	28030	Differential Feed Control Lever (Inner)	送り調節中レバー	1
21	4100	Screw for 28030	送り調節中レバー止ネジ	1
22	5098	Screw for 28030	送り調節中レバー止ネジ	1
23	33141	Feed Adjusting Eccentric Pin	エキセンピン	1
24	235	Oil Wick for 33141	油芯	1
25	28064	Feed Bar, Complete Set	送り台 (組)	1
26	28018	Differential Feed Bar	前送り台	1
27	33099	Feed Bar Driving Stud (Long)	送りリンクピン (長)	1
28	687	Pin for Feed Bar Driving Stud	ピン	2
29	34138	Feed Bar Driving Stud (Short)	送りリンクピン (短)	1
30	28019	Main Feed Bar	後送り台	1
31	93383	Feed Lifter Block Roller Bearing	角駒 (大) ニードルベアリング	1
32	93382	Feed Lifter Block	角駒 (大)	1
33	60076	Feed Lifter Block Out Retaining Ring	角駒 (大) スペースリング	1
34	28081	Differential Feed Dog	前送り	1
35	7609	Screw for 28081	前送り止ネジ	1
36	28082	Main Feed Dog	後送り	1
37	1202	Screw for 28082	後送り止ネジ	1
38	28083	Auxiliary Feed Dog	小送り	1
39	1222	Screw for 28083	小送り止ネジ	1
40	32867	Feed Bar Guide Block	角駒 (小)	1
41	28015	Feed Bar Guide (Rear)	送り台ガイド (後)	1
42	3646	Screw for 28015	送り台ガイド (後) 止ネジ	1
43	3635	Screw for 33141	エキセンピン止ネジ	1
44	20072	Rubber Cushion	埋メ座 (中)	1
45	28023	Differential Feed Bar Driving Connecting Rod	前送りロッド	1
46	34137	Main Feed Bar Driving Connecting Bushing	後送りリンクブッシュ	1
47	34141	Feed Driving Eccentric Roller Bushing	送りリンクニードルベアリング	2
48	34150	Feed Driving Eccentric	送り前後エキセン	2
49	28024	Main Feed Bar Driving Connection	後送りリンク	1
50	605	Washer for Feed Driving Eccentric	エキセン止メワッシャ	1
51	20	Nut for Feed Driving Eccentric	エキセン止メナット	1
52	33105	Feed Bar Driving Shaft Lever	送り軸腕	1
53	95150	Differential Feed Bar Driving Lever	前送りロッドピン	1
54	7006	Screw for 95150	前送りロッドピン止ネジ	1
55	1114	Oil Wick for 95150	油芯	1
56	28011	Feed Bar Driving Shaft	送り軸	1
57	639	Seal Plug for 28011	詰栓	2

From the library of: Diamond Needle Corp

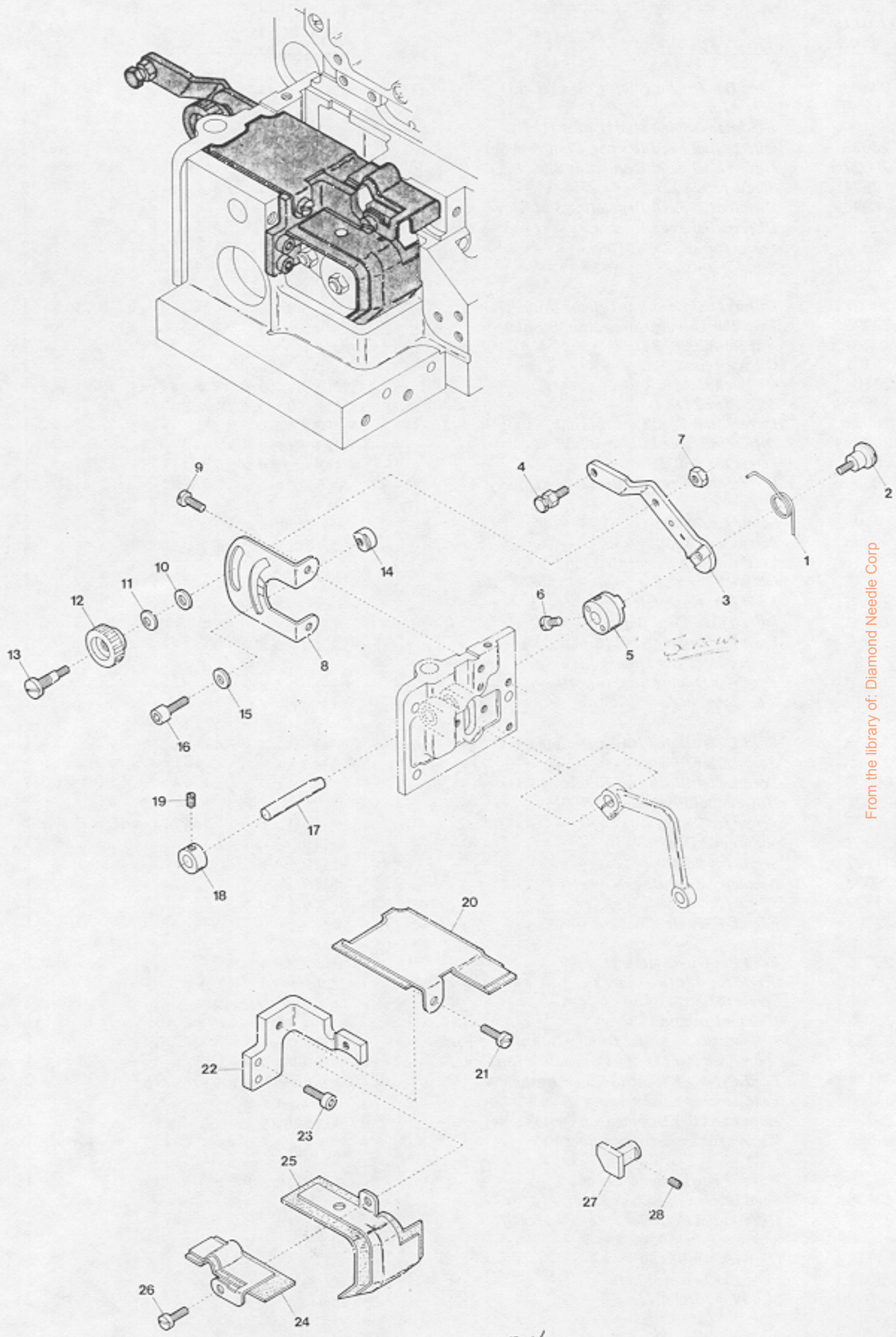

From the library of: Diamond Needle Corp

Ref. No.	Parts No.	Description	品名	Amt. Req.
1	28037	Differential Feed Control Lever Spring	調節外レバーバネ	1
2	7151	Screw for 28037	調節外レバーバネ止ネジ	1
3	28036	Differential Feed Control Lever (Outer)	前送り調節外レバー	1
4	4143	Screw for Hanging Chain	鎖掛ケネジ	1
5	28035	Differential Feed Control Lever Collar	調節外レバー取付カラー	1
6	5000	Screw for 28035	調節外レバー取付カラー止ネジ	2
7	334	Nut for 28036	ナット	1
8	28039	Differential Feed Graduations	送り目盛板	1
9	4353	Screw for 28039	送り目盛板止ネジ	2
10	520	Washer for 28036	ワッシャ	1
11	561	Spring Washer for 28036	スプリングワッシャ	1
12	181	Adjusting Nut for 28036	調節ナット	1
13	4111	Adjusting Screw for 28036	調節ネジ	1
14	20420	Differential Feed Control Lever Stopper	調節外レバーストッパ	2
15	186	Washer for 20420	ワッシャ	2
16	5038	Screw for 20420	調節外レバーストッパ止ネジ	2
17	28032	Differential Feed Control Lever Shaft	前送り調節レバー軸	1
18	34505	Differential Feed Control Lever Shaft Collar	前送り調節レバー軸カラー	1
19	1459	Screw for 34505	前送り調節レバー軸カラー止ネジ	2
20	28061	Feed Bar Cover	送り台カバー	1
21	4095	Screw for 28061	送り台カバー止ネジ	1
22	28017	Feed Bar Guide (Left)	送り台ガイド (左)	1
23	5098	Screw for 28017	送り台ガイド (左) 止ネジ	2
24	28057	Feed Bar Shield	送り台油除ケ	1
25	28059	Feed Bar Cover (Front)	送り台カバー (前)	1
26	5036	Screw for 28059	送り台カバー (前) 止ネジ	1
27	28016	Feed Bar Guide (Right)	送り台ガイド (右)	1
28	3638	Screw for 28016	送り台ガイド (右) 止ネジ	1

From the library of: Diamond Needle Corp.

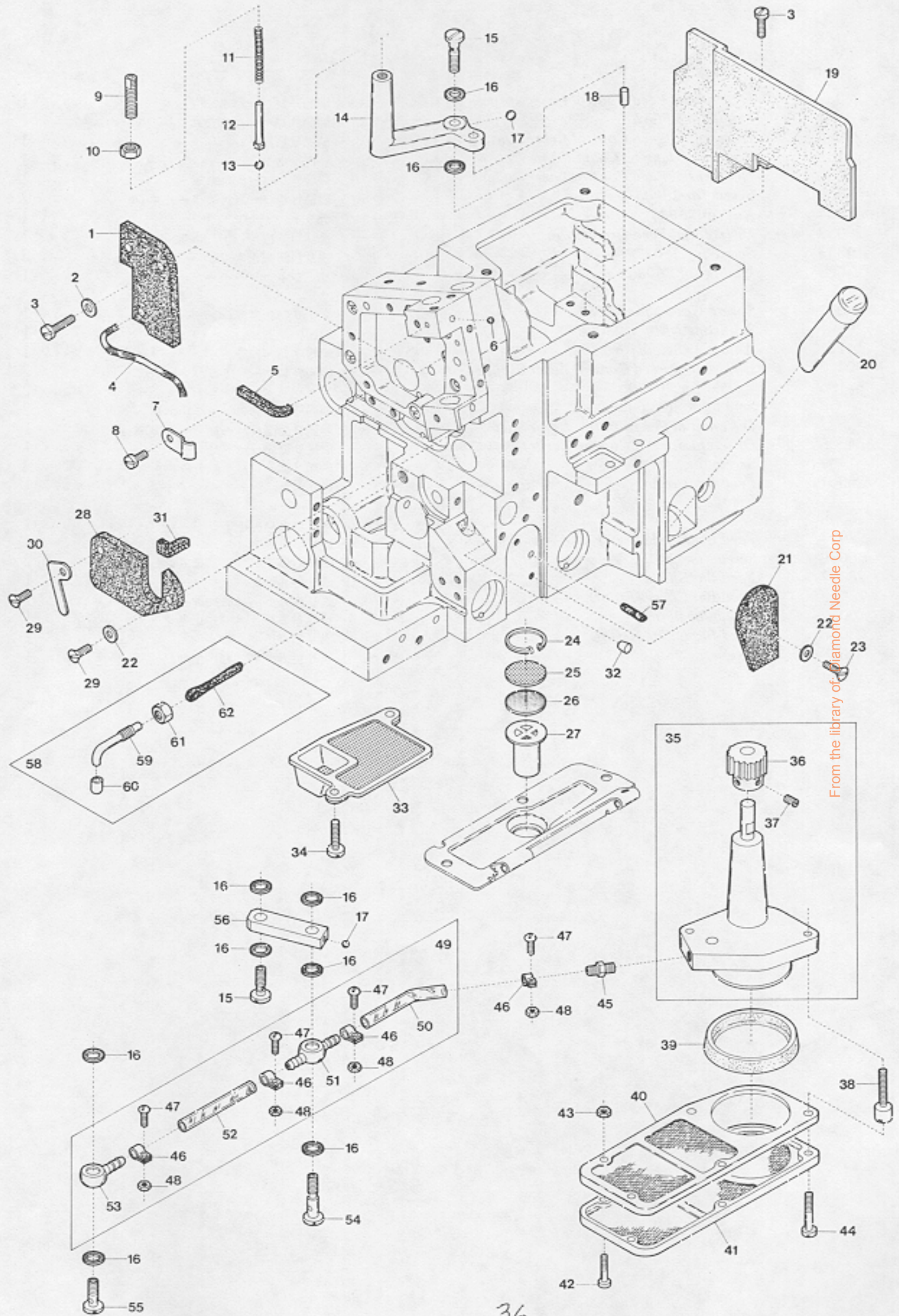

Ref. No.	Parts No.	Description	品名	Amt. Req.
1	26030	Needle Bar Oiling Felt (Right)	針棒フェルト (右)	1
2	542	Washer for 26030	ワッシャ	2
3	4440	Screw for 26030, 26025	止ネジ	4
4	235	Oil Wick for 26030	油芯	1
5	241	Oil Wick for Needle Bar Bushing (Upper)	油芯	1
6	637	Oil Seal Plug	詰栓	1
7	26028	Oil Wick Holder	油芯支エ	1
8	1202	Screw for 26028	油芯支エ止ネジ	1
9	20534	Oil Sight Nozzle	ノズル	1
10	419	Nut for 20534	ナット	1
11	30745	Oil Pressure Regulating Valve Spring	調圧弁バネ	1
12	30478	Oil Pressure Regulating Valve Spring Guide	調圧弁バネ案内ピン	1
13	80503	Oil Pressure Regulating Ball	調圧ボール弁	1
14	20535	Oil Pressure Regulating Valve	調圧弁座	1
15	4124	Oil Tube Fitting Stud (Short)	管継手ボルト (短)	2
16	567	Seal for 20535, 37668, 33980, 20539	パッキン	9
17	638	Seal Plug for 20535, 20539	詰栓	2
18	651	Pin for 20535	ピン	1
19	26025	Oil Defender	油除ケ	1
20	20533	Oil Sight Gauge	オイルゲージ	1
21	20325	Upper Looper Bar Oiling Felt	ルーバフェルト	1
22	538	Washer for 20325, 26031	ワッシャ	3
23	7619	Screw for 20325	ルーバフェルト止ネジ	2
24	20020	Filter Screen Clamp	前カバー濾過網押エ	1
25	20019	Front Cover Filter Screen (Course Mesh)	前カバー濾過網 (荒目)	1
26	24166	Front Cover Filter Screen	前カバー濾過網	1
27	24167	Front Cover Filter Screen Holder	前カバー濾過網受ケ	1
28	26031	Top Feed Dog Bar Oiling Felt	上送り台フェルト	1
29	7621	Screw for 26031, 26027	止ネジ	2
30	26027	Top Feed Dog Bar Oiling Felt Holder	上送り台フェルト押エ	1
31	321	Oil Wick for Top Feed Dog Bar	油芯	1
32	760	Seal Plug for Machine Frame	詰栓	1
33	28052	Feed Mechanism Filter Screen	送り濾過網	1
34	9150	Screw for 28052	送り濾過網止ネジ	2
35	20526	Oil Pump, Complete Set	ポンプ (組)	1
36	20520	Worm Wheel	ウォームホイール	1
37	4108	Screw for 20520	ウォームホイール止ネジ	2
38	4115	Screw for 20526	ポンプ (組) 止ネジ	2
39	20530	Pump Filter Screen Sleeve	ポンプ濾過網スリーブ	1
40	20531	Pump Filter Screen (Upper)	ポンプ濾過網 (上)	1
41	20532	Pump Filter Screen (Lower)	ポンプ濾過網 (下)	1
42	4116	Screw for 20531, 20532	ポンプ濾過網止ネジ	3
43	180	Nut for 20531, 20532	ナット	3
44	5004	Screw for 20531, 20532	ポンプ濾過網止ネジ	2
45	9909	Oil Tube Fitting Nut	パイプ継手	1
46	32944	Oil Tube Clamp	緊束環	4
47	9989	Screw for 32944	緊束環止ネジ	4
48	15	Nut for 32944	ナット	4
49	20554	Oil Lubricating Tube, Complete Set	給油パイプ (組)	1
50	33668	Oil Tube (4x6x50mm)	給油パイプ	1
51	37668	Oil Tube Fitting Two Way	両口管継手	1
52	32949	Oil Tube (4x6x58mm)	給油パイプ	1
53	33980	Oil Tube Fitting One Way End	片口管継手	1
54	4126	Oil Tube Fitting Stud (Long)	管継手ボルト (長)	1
55	7668	Oil Tube Fitting Stud (Short)	管継手ボルト (短)	1
56	20539	Lubricant Guiding Block	給油ブロック	1
57	376	Oil Wick for Machine Frame	油芯	1
58	28063	Oil Nozzle, Complete Set	オイルパイプ (組)	1
59	28055	Oil Nozzle	オイルパイプ	1
60	37697	Oil Nozzle Cap	注油キャップ	1
61	419	Nut for 28055	ナット	1
62	—	Oil Wick for 28055	油芯	1

From the library of: Diamond Needle Corp

UPPER KNIFE(Angled type)

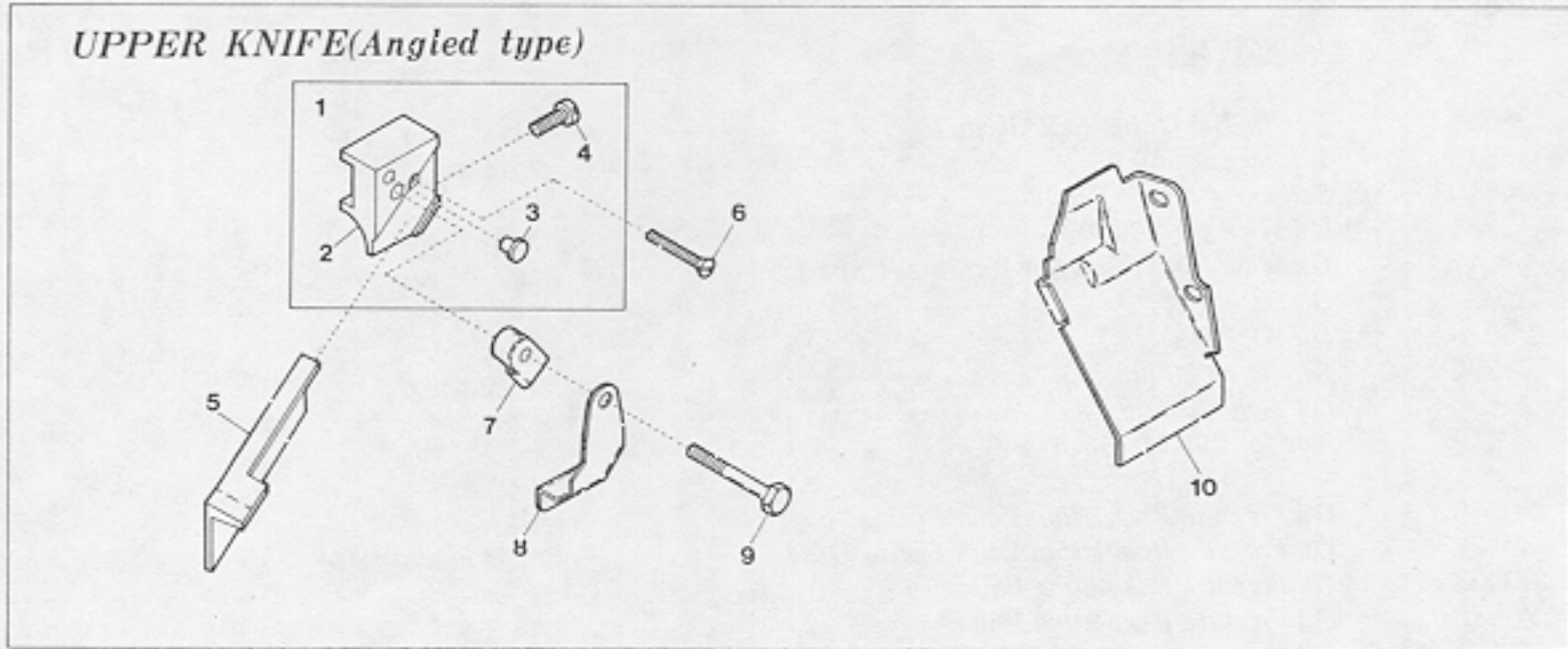

From the library of: Diamond Needle Corp

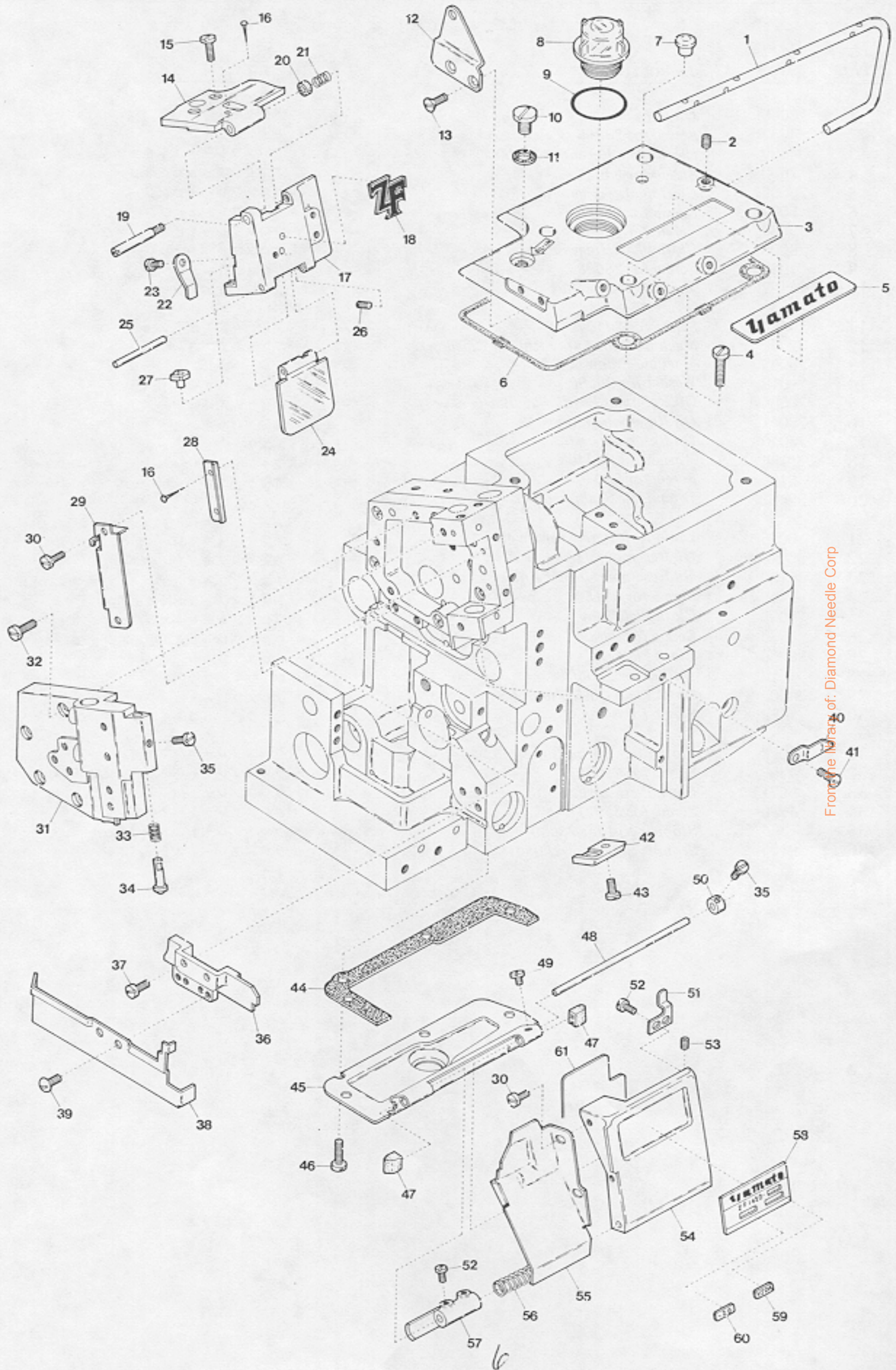

EXCLUSIVE PARTS for UPPER KNIFE(Angled Type) 角メス専用部品 **17**

<u>Ref. No.</u>	<u>Parts No.</u>	<u>Description</u>	<u>品名</u>	<u>Amt. Req.</u>
1	22198	Upper Knife Holder, Complete Set	上メスホルダ (角) (組)	1
2	22778	Upper Knife Holder	上メスホルダ	1
3	20489	Upper Knife Holder Packing	上メスホルダ埋メ座	1
4	4404	Stopper Screw for 20491	上メスストップバネジ	1
5	20491	Upper Knife	上メス	1
6	4105	Screw for 22778	上メスホルダ止ネジ	1
7	20492	Upper Knife Clamp	上メス押エ	1
8	22759	Upper Knife Chip Guard	切屑押し	1
9	4104	Screw for 22759	切屑押し止ネジ	1
10	28044	Chip Guard (Openable)	切屑落シ板	1

From the library of: Diamond Needle Corp

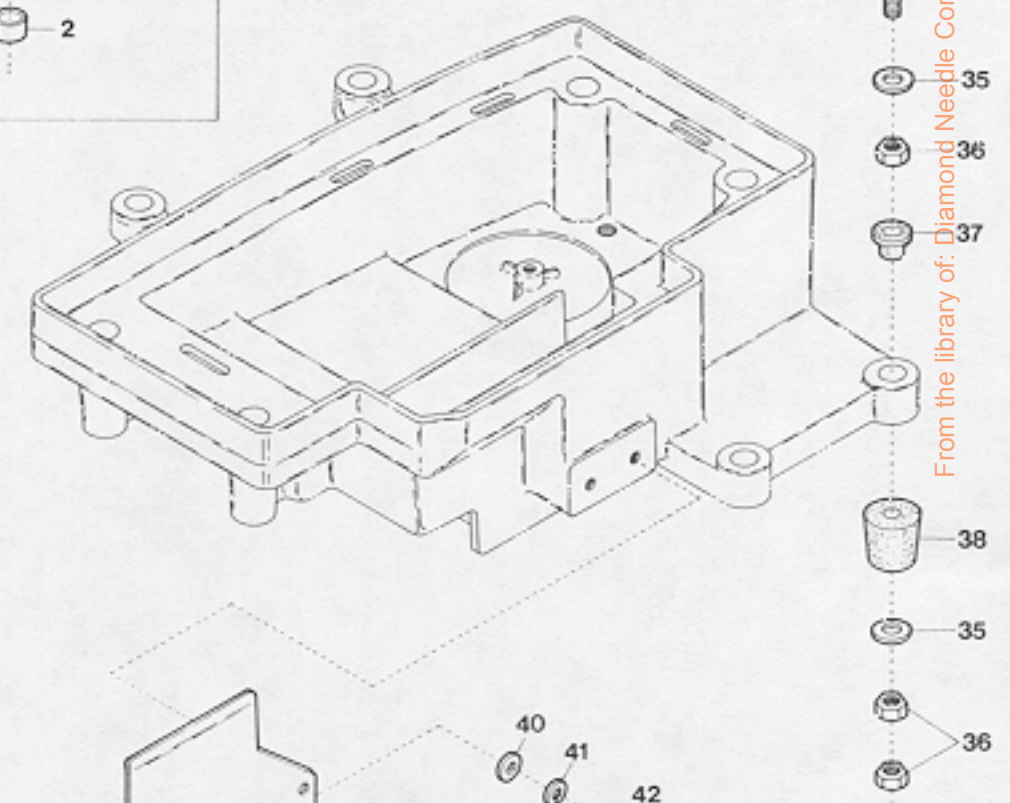
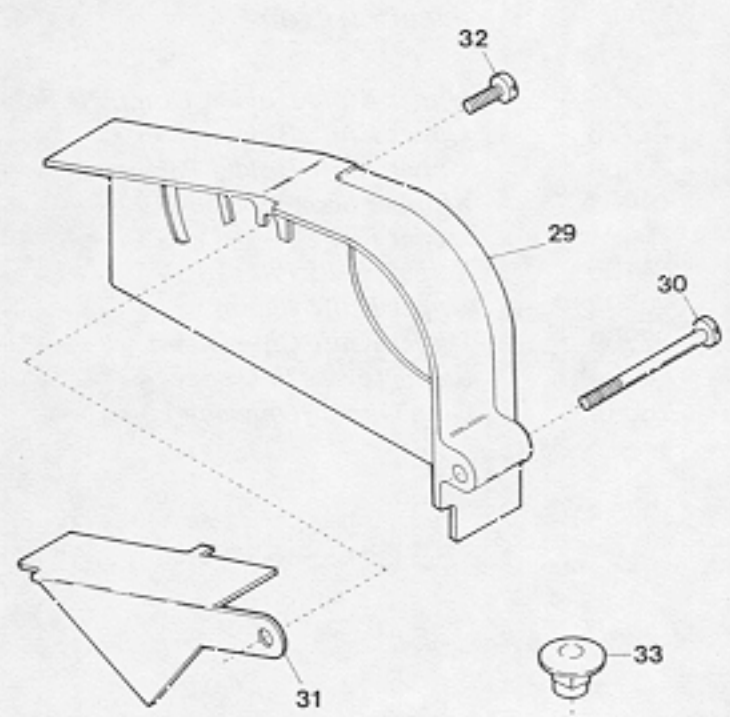
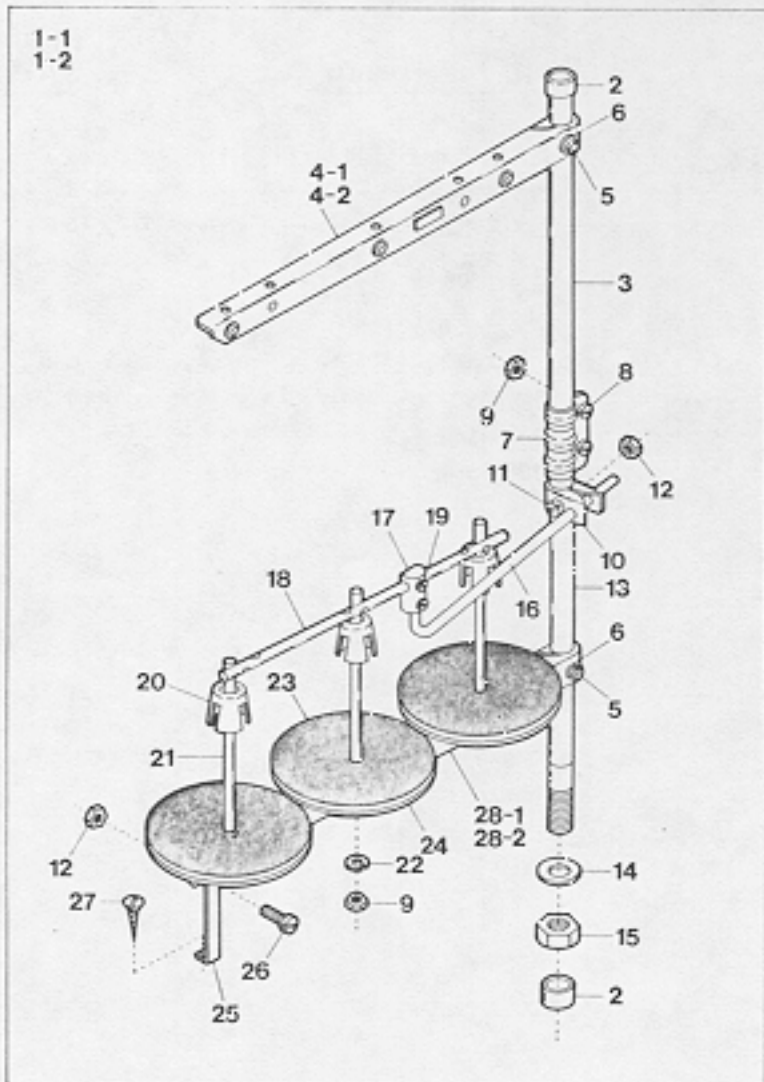

From the library of: Diamond Needle Corp

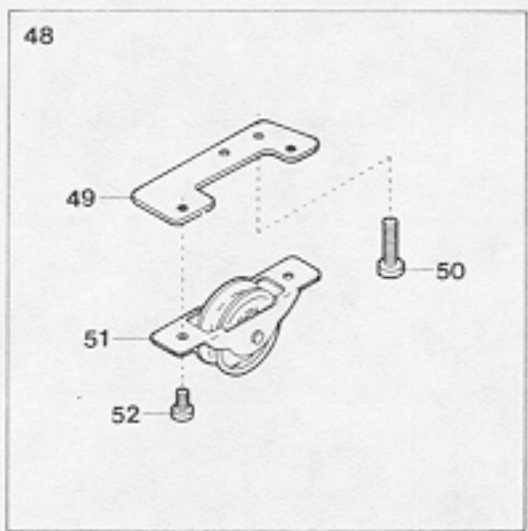
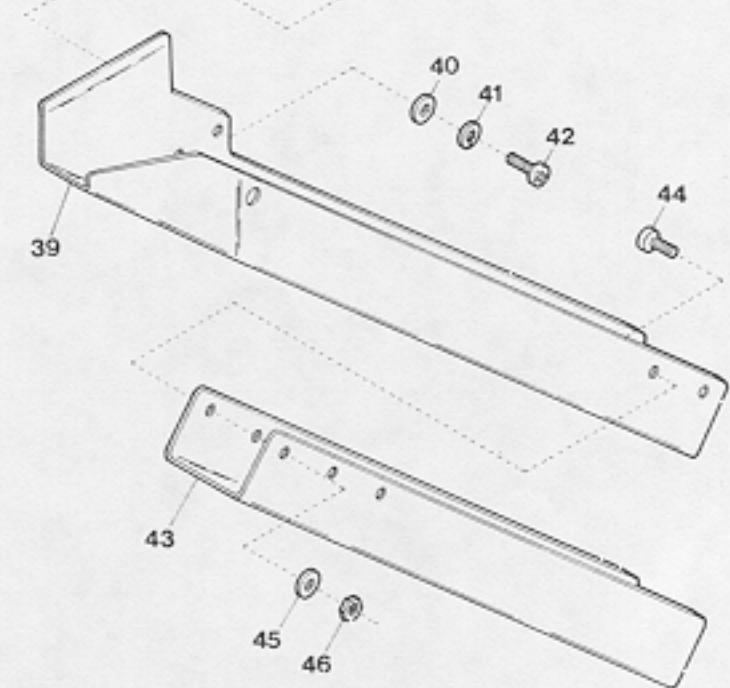
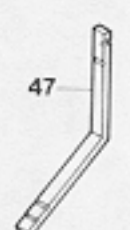

Ref. No.	Parts No.	Description	品名	Amt. Req.
1-1	99072	Thread Stand, Complete Set (3 Spools Type)	糸立台 (組) (3本糸用)	1
1-2	99073	" " (4 Spools Type)	" (4本糸用)	1
2	99057	Column Cap	コラムキャップ	2
3	99058	Column Pipe (Upper)	コラムパイプ (上)	1
4-1	99060	Thread Hanger (3 Spools Type)	スレッドハンガ (3本糸用)	2
4-2	99059	Thread Hanger (2 Spools Type)	" (2本糸用)	1
5	147	Screw for 99060, 99059, 99070, 99071	止ネジ	2
6	148	Washer for 99060, 99059, 99070, 99071	ワッシャ	2
7	99061	Column Pipe Connector	コラムパイプ継手	1
8	149	Screw for 99061	コラムパイプ継手止ネジ	2
9	150	Nut for 99061, 99066	ナット	5
10	99062	Thread Guide Holder	糸案内ホルダ	1
11	151	Screw for 99062	糸案内ホルダ止ネジ	1
12	152	Nut for 99062, 99069	ナット	2
13	99063	Column Pipe (Lower)	コラムパイプ (下)	1
14	154	Washer for 99063	ワッシャ	1
15	153	Nut for 99063	ナット	2
16	99030	Thread Guide Bar	糸案内支エ棒	1
17	99031	Thread Guide Bar Bracket	支エ棒接点	1
18	99064	Thread Guide	糸案内	1
19	156	Screw for 99064	糸案内止ネジ	2
20	99065	Spool Cushion	スプールクッション	3
21	99066	Spool Pin	スプール軸	3
22	157	Spring Washer for 99066	スプリングワッシャ	3
23	99067	Spool Mat	スプールマット	3
24	99068	Spool Seat Disc	受ヶ皿	3
25	99069	Spool Holder Stay	スプールホルダ支エ	1
26	158	Screw for 99069	スプールホルダ支エ止ネジ	1
27	159	Wood Screw for 99069	木ネジ	1
28-1	99070	Spool Holder (3 Spools Type)	スプールホルダ (3本糸用)	2
28-2	99071	" " (2 Spools Type)	" (2本糸用)	1
29	24089	Belt Cover (Large)	ベルトカバー (大)	2
30	4089	Screw for 24089	ベルトカバー (大) 止ネジ	1
31	24090	Belt Cover (Small)	ベルトカバー (小)	1
32	4635	Screw for 24090	ベルトカバー (小) 止ネジ	1
33	160	Hanging Nut for 28040	吊リナット	4
34	164	Hanging Bolt for 28040	吊リボルト	4
35	162	Washer for 28040	ワッシャ	4
36	161	Nut for 28040	ナット	12
37	20064	Oil Reservoir Rubber Cushion	油受ヶゴム座	4
38	32976	Oil Reservoir Rubber Cushion	油受ヶゴム座	4
39	28053	Shute (Upper)	シュート (上)	1
40	665	Washer for 28053	ワッシャ	2
41	644	Spring Washer for 28053	スプリングワッシャ	4
42	9992	Screw for 28053, 20077	止ネジ	4
43	28054	Shute (Lower)	シュート (下)	1
44	4127	Screw for 28054	シュート (下) 止ネジ	4
45	538	Washer for 28054	ワッシャ	4
46	15	Nut for 28054	ナット	4
47	26266	Timing Gauge (Extra)	タイミングゲージ (特注品)	1
48	20078	Idler, Complete Set (for Left Footing Pedal)	アイドラ (組) (左足ペダル用)	1
49	20077	Idler Support	アイドラ取付板	1
50	20076	Idler	アイドラ	1
51	9995	Screw for 20076	アトドラ止ネジ	2

From the library of: Diamond Needle Corp

INDEX

Parts No.	Page No.	Ref. No.	Weight (g)
10	3	12	0.2
15	16	48	0.7
15	17	46	0.7
20	14	51	6
147	18	5	4
148	18	6	0.5
149	18	8	1.5
150	18	9	0.8
151	18	11	4.5
152	18	12	1.5
153	18	15	1
154	18	14	5
156	18	19	1
157	18	22	0.7
158	18	26	2
159	18	27	3
160	18	33	22.5
161	18	36	5.5
162	18	35	3.9
164	18	34	27
171	12	27	—
177	4	8	0.06
178	4	6	0.3
180	16	43	0.2
181	15	12	13
184	1	18	3.2
186	9	13	1
186	15	15	1
192	14	14	0.5
198	4	48	0.5
199	5	36	1
224	5	33	—
235	14	24	—
235	16	4	—
240	4	49	—
241	16	5	—
242	9	10	—
265	12	28	—
278	5	32	0.03
278	6	14	0.03
278	12	22	0.03
280	9	24	0.2
290	5	35	0.01
321	16	31	0.01
322	4	23	0.3
322	8	14	0.3
325	5	31	1
334	1	35	0.6
334	9	3	0.6
334	11	14	0.6
334	15	7	0.6
335	8	31	0.8
340	4	11	0.5

Parts No.	Page No.	Ref. No.	Weight (g)
376	16	57	—
396	2	20	1
396	9	21	1
419	16	61	1
419	16	10	1
444	4	37	0.09
449	11	2	—
451	14	13	1.5
507	12	14	—
520	6	5	0.3
520	7	6	0.3
520	12	19	0.3
520	13	17	0.3
520	15	10	0.3
525	2	11	0.1
526	5	29	0.04
528	1	28	1.85
532	4	41	0.3
532	7	17	0.3
533	11	33	0.3
538	9	7	0.4
538	16	22	0.4
538	18	45	0.4
542	16	2	0.3
550	3	18	0.03
561	15	11	0.5
567	14	10	0.07
567	16	16	0.07
605	14	50	5
613	1	14	1
613	9	9	1
633	3	30	—
636	13	7	0.02
637	6	8	0.07
637	12	9	0.07
637	16	6	0.07
638	12	5	0.16
638	13	11	0.16
638	16	17	0.16
639	6	10	0.21
639	7	11	0.21
639	14	57	0.21
644	4	22	0.8
644	18	41	0.8
651	16	18	1
665	18	40	—
687	11	42	0.1
687	14	28	0.1
688	13	26	2
726	2	16	0.04
755	11	13	0.2

Parts No.	Page No.	Ref. No.	Weight (g)
760	16	32	—
916	2	5	—
926	5	51	0.06
1047	2	18	—
1095	4	31	1
1110	11	28	—
1112	11	12	—
1113	10	29	—
1114	14	55	—
1115	11	25	—
1116	11	17	—
1117	10	33	—
1170	5	15	0.1
1186	6	18	1
1202	2	43	0.8
1202	3	21	0.8
1202	8	17	0.8
1202	9	5	0.8
1202	14	37	0.8
1202	16	8	0.8
1203	3	34	0.1
1222	14	39	0.5
1223	2	15	0.55
1223	3	10	0.55
1223	8	13	0.55
1227	4	38	0.3
1228	2	35	0.2
1228	4	27	0.2
1228	8	8	0.2
1230	10	31	0.2
1326	4	35	1
1330	4	42	0.6
1331	2	39	—
1331	3	44	—
1435	11	15	—
1457	12	8	0.6
1459	1	30	0.1
1459	2	26	0.1
1459	5	6	0.1
1459	15	19	0.1
2022	5	52	1
2022	11	40	1
2590	2	61	—
3313	6	15	0.1
3313	12	23	0.1
3434	5	13	0.4
3436	8	11	0.6
3635	2	2	0.9
3635	8	35	0.9
3635	14	43	0.9
3635	10	5	0.9
3636	5	28	0.9

From the library of: Diamond Needle Corp

INDEX

Parts No.	Page No.	Ref. No.	Weight (g)
3637	2	53	0.1
3637	6	21	0.1
3637	8	4	0.1
3637	9	26	0.1
3637	10	34	0.1
3637	11	21	0.1
3638	5	9	0.5
3638	6	7	0.5
3638	8	33	0.5
3638	10	12	0.5
3638	12	43	0.5
3638	13	20	0.5
3638	15	28	0.5
3646	14	42	0.9
3654	5	16	3.5
3655	7	23	0.7
4089	18	30	8
4094	9	11	—
4095	15	21	—
4097	8	47	—
4100	14	21	3
4103	8	24	13.5
4104	17	9	2
4105	17	6	0.3
4106	7	18	1.1
4106	11	34	1.1
4107	8	21	3
4108	16	37	0.4
4111	15	13	4
4115	16	38	6.7
4116	16	42	1
4123	5	2	1.5
4124	16	15	4
4126	16	54	5.3
4127	18	44	0.8
4130	13	23	0.6
4141	8	45	0.16
4143	15	4	2.5
4144	12	34	0.28
4209	8	1	—
4236	1	34	0.34
4236	3	27	0.34
4237	8	55	0.2
4265	4	9	7
4270	11	9	4
4272	11	1	40
4313	6	16	0.4
4317	7	20	0.5
4351	8	50	0.8
4351	9	23	0.8
4352	8	30	1.3
4353	4	50	0.9
4353	11	44	0.9
4353	15	9	0.9

Parts No.	Page No.	Ref. No.	Weight (g)
4358	1	32	0.9
4358	12	36	0.9
4401	3	23	0.3
4404	6	27	0.25
4404	17	4	0.25
4406	3	15	1.18
4406	6	24	1.18
4406	10	10	1.18
4410	12	4	2
4435	3	37	1.05
4437	1	2	1.5
4437	13	8	1.5
4440	1	11	1.5
4440	2	46	1.5
4440	3	19	1.5
4440	9	17	1.5
4440	16	3	1.5
4445	2	32	2
4446	9	2	—
4635	18	32	4
5000	2	30	0.62
5000	4	25	0.62
5000	15	6	0.62
5004	16	44	2.3
5036	1	26	0.6
5036	3	32	0.6
5036	7	26	0.6
5036	13	25	0.6
5036	15	26	0.6
5038	9	14	2
5038	15	16	2
5043	3	2	1.76
5044	8	43	0.3
5065	11	23	0.5
5070	6	2	5
5070	7	2	5
5070	12	2	5
5070	13	2	5
5071	10	2	2
5075	2	10	10
5076	1	21	8
5078	3	36	2.8
5083	2	4	3.85
5087	1	6	4
5089	1	7	4
5098	14	22	1.5
5098	15	23	1.5
5108	1	19	6
5108	12	15	6
5108	13	15	6
5118	8	57	4.2
5343	2	13	0.78
5345	3	7	0.9
5401	6	25	1

Parts No.	Page No.	Ref. No.	Weight (g)
5500	13	18	5
5512	14	19	1
5520	3	29	5
5520	6	4	5
5520	7	7	5
5520	10	7	5
5520	14	9	5
5522	12	20	10
5550	7	10	3
5550	8	29	3
5550	11	7	3
5550	12	11	3
5550	14	2	3
6004	3	13	3
6035	4	21	1.3
6094	8	19	0.5
7006	1	9	0.7
7006	2	23	0.7
7006	14	54	0.7
7128	4	12	0.8
7151	15	2	—
7311	12	41	0.9
7405	7	15	0.2
7609	10	36	0.15
7609	14	35	0.15
7616	2	49	0.36
7616	3	39	0.36
7616	14	16	0.36
7619	4	45	0.34
7619	16	23	0.34
7621	16	29	—
7645	5	53	0.4
7650	1	4	0.35
7668	16	55	4
7906	4	14	7
8101	13	3	1.6
9106	1	36	3
9121	2	41	0.6
9121	13	22	0.6
9150	1	24	2
9150	9	8	2
9150	16	34	2
9503	8	6	1
9503	11	4	1
9508	7	4	1
9508	12	30	1
9526	11	18	0.2
9533	8	15	—
9604	11	32	0.9
9604	13	10	0.9
9624	14	6	0.4
9730	2	52	0.6

From the library of Diamond Needle Corp.

INDEX

Parts No.	Page No.	Ref. No.	Weight (g)
9853	2	37	1.6
9853	13	5	1.6
9909	16	45	2
9989	16	47	1
9992	18	42	2
9995	18	52	0.4
18692	2	58	—
18728	2	60	—
20004	2	8	8
20005	2	9	1.25
20019	16	25	0.8
20020	16	24	0.7
20064	18	37	2.4
20072	14	44	0.5
20076	18	51	32
20077	18	49	—
20078	18	48	120
20080	1	15	24.5
20101	4	15	9
20108	4	40	1.2
20110	4	39	0.8
20112	12	35	2.8
20118	4	5	0.95
20131	4	30	0.1
20154	5	3	64
20157	5	14	94
20271	8	46	0.5
20293	8	18	0.6
20320	12	26	10
20322	12	40	11
20323	12	42	4.9
20325	16	21	0.8
20330	12	37	1.5
20331	12	21	3
20334	5	41	1.8
20420	9	12	2.3
20420	15	14	2.3
20487	7	8	2.4
20489	17	3	0.3
20490	7	13	1
20491	17	5	5
20492	17	7	2.6
20496	7	16	2.8
20520	16	36	32
20526	16	35	445
20530	16	39	5
20531	16	40	15
20532	16	41	22
20533	16	20	22
20534	16	9	2.3
20535	16	14	50
20538	3	35	0.1
20539	16	56	26
20554	16	49	—

Parts No.	Page No.	Ref. No.	Weight (g)
20817	2	59-1	—
20818	2	59-2	—
21124	4	46	13.4
21700	12	32	1.6
21701	13	19	5
21703	13	16	36.6
21705	12	33	1.2
21713	4	34	42.7
21714	4	36	0.6
21717	13	21	3.6
21720	4	33	1.8
22195	7	21	6.25
22198	17	1	—
22215	4	16	4
22257	8	16	2.2
22259	2	27	1
22261	2	33	0.5
22371	2	21	0.55
22554	12	18	—
22759	17	8	2.3
22764	2	34	2
22778	17	2	3.8
22854	12	29	—
22970	4	10	24
23234	11	24	1
23468	12	39	—
24004	6	1	50
24005	6	3	37
24008	6	17	9
24010	3	9	13
24011	2	29	10
24014	5	25	9
24016	5	30	17
24021	8	10	0.2
24023	8	5	42
24024	8	7	0.5
24025	2	17	24
24026	2	19	3
24028	2	24	4.3
24043	2	55	45
24050	4	32	2
24051	5	1	—
24053	5	18	11
24054	5	42	—
24055	5	43	—
24056	5	44	24
24057	5	45	18
24058	5	46	5
24063	12	16	45
24064	13	1	50
24065	13	6	51

Parts No.	Page No.	Ref. No.	Weight (g)
24068	13	14	42
24069	13	13	42
24072	2	47	0.6
24077	13	12	43
24080	8	20	10
24081	7	14	10
24082	2	25	1.5
24083	4	2	0.4
24084	4	1	4
24085	2	51	2
24086	4	26	—
24089	18	29	—
24090	18	31	—
24091	3	4	24
24092	3	3	0.5
24093	3	1	36
24094	6	6	6
24095	2	56	1.4
24104	10	6	35
24131	4	19	4.6
24132	6	20	3.6
24138	8	2	5
24139	8	3	8
24141	8	39	25
24154	2	48	11
24156	4	3	1.4
24157	4	13	2
24159	2	22	1.1
24165	2	40	0.6
24166	16	26	0.1
24167	16	27	2
24169	13	24	2.6
24184	14	15	1.7
24188	2	28	1.2
24191	12	1	—
24192	12	13	45
24193	12	6	10
24194	12	3	5
24195	12	7	5
24197	1	10	62
24321	4	20	—
24481	12	25	19
26004	2	31	127
26007	2	6	6
26008	3	14	61
26009	3	16	1.2
26010	2	14	27
26011	3	17	47
26012	3	20	54
26015	2	36	33
26016	2	38	31
26020	4	51	4.5
26021	4	44	11
26022	2	1	69

From the library of: Diamond Needle Corp

INDEX

Parts No.	Page No.	Ref. No.	Weight (g)
26023	2	12	18
26024	4	43	31
26025	16	19	54
26027	16	30	1.5
26028	16	7	1.2
26029	10	30	1.8
26030	16	1	1.8
26031	16	28	0.9
26035	5	26	30
26036	5	27	0.5
26037	12	12	3.8
26038	12	10	15
26039	8	56	27
26042	6	11	95
26043	5	34	6
26044	7	1	35
26045	5	20	17
26046	5	19	22
26049	8	40	12
26050	8	37	19
26051	8	44	2.5
26053	8	41	71
26054	8	34	80
26055	5	38	8
26056	8	28	38
26057	8	27	2.1
26058	8	22	55
26059	8	26	11
26060	8	12	10
26062	8	36	57
26064	8	9	10
26065	8	23	5
26066	7	12	132
26067	5	37	—
26068	11	29	47
26069	5	23	13
26070	5	22	22
26071	5	24	0.7
26072	11	27	6.5
26073	11	20	1
26074	11	30	15
26075	11	35	3
26076	11	36	7
26077	11	38	18
26078	11	37	1
26088	10	25	67
26089	5	40	51
26090	5	39	44
26091	10	9	2.1
26092	3	5	3.2
26098	10	26	68
26099	10	16	1.2
26101	10	28	12

Parts No.	Page No.	Ref. No.	Weight (g)
26104	10	20	3
26107	11	11	61
26109	11	16	2.5
26112	9	4	34
26117	11	3	60
26118	11	5	12
26119	11	6	34
26120	11	8	0.5
26122	11	39	15
26123	9	1	9
26125	11	22	3
26126	11	20	31
26140	8	53	0.4
26142	8	54	1.5
26260	2	42	6.2
26263	7	5	55
26264	12	24	61
26265	12	17	96
26266	18	47	—
26301	2	3	452
26400	5	8	82
26401	10	1	42
26402	10	4	10
26403	5	7	6
26406	10	8	80
26407	5	47	15
26408	10	24	44
26409	10	23	5
26410	10	22	53
26411	10	21	4
26412	10	19	17
26413	10	18	1
26414	10	13	16
26415	10	15	59
26416	10	27	16
26417	11	19	22
26418	10	32	1.2
26419	5	12	115
26420	5	4	12
26421	11	41	2.5
26422	11	43	1.3
26424	11	10	135
26425	9	6	82
26426	5	5	15
26427	9	16	52
26428	9	19	12
26429	9	22	4.9
26430	9	18	5.2
26431	9	25	24
26432	8	42	2.7
26433	10	14	91
26434	9	15	110
26438	9	20	1.1

Parts No.	Page No.	Ref. No.	Weight (g)
26513	10	35	10
27023	8	51	0.5
28001	3	28	—
28002	3	24	—
28003	3	31	4
28004	3	25	45
28005	1	25	—
28006	1	5	—
28008	1	8	1.2
28009	5	10	450
28010	5	17	45
28011	14	56	68
28012	5	48	18
28013	5	49	7
28014	5	50	18.5
28015	14	41	28
28016	15	27	7.1
28017	15	22	40
28018	14	26	58.3
28019	14	30	53.3
28022	14	11	14
28023	14	45	33
28024	14	49	18
28025	14	8	30
28026	14	7	6
28027	14	5	2.5
28028	14	4	—
28029	14	18	10
28030	14	20	17
28031	14	17	31
28032	15	17	7
28035	15	5	—
28036	15	3	16
28037	15	1	—
28038	5	54	—
28039	15	8	2.5
28040	1	17	21
28041	1	16	114
28042	2	45	122
28043	2	44	1.1
28044	17	10	45
28047	3	11	—
28048	3	33	20
28050	1	27	318
28052	16	33	9
28053	18	39	—
28054	18	43	—
28055	16	59	—
28057	15	24	5
28059	15	25	11
28061	15	20	20
28062	1	13	—
28063	16	58	5
28064	14	25	—

45

From the library of: Diamond Needle Corp.

INDEX

Parts No.	Page No.	Ref. No.	Weight (g)
28066	1	1	—
28068	2	54	—
28069	2	57	—
28071	3	38	—
28072	3	41	—
28073	3	40	—
28074	3	42	—
28075	3	43	—
28080	6	23-1	18
28081	14	34	14
28082	14	36	5
28083	14	38	1.5
28084	6	26	—
28085	7	22	20
28086	7	19	2.6
28088	6	23-2	18
28102	8	52-1	—
28103	8	52-2	—
28104	8	48-1	—
28105	8	48-2	—
28106	8	49	—
30228	8	32	9
30228	10	11	9
30228	11	31	9
30228	13	9	9
30745	16	11	0.4
30748	16	12	0.7
31111	4	7	5
32421	1	20	0.1
32425	4	29	0.4
32612	2	7	0.4
32646	6	9	11.8
32684	5	21	1
32756	7	24	1
32780	5	11	0.2
32812	12	38	0.01
32867	14	40	2.8
32920	7	9	15.5
32921	7	3	7
32944	16	46	2
32949	16	52	—
32971	4	4	2
32976	1	12	8
32976	18	38	8
33013	3	6	14
33024	10	17	0.1
33057	13	4	7
33081	2	50	0.3
33098	14	12	2
33099	14	27	3.6
33104	14	3	18
33105	14	52	33
33141	14	23	12
33668	16	50	1

Parts No.	Page No.	Ref. No.	Weight (g)
33980	16	53	—
34137	14	46	2.5
34138	14	29	3
34141	14	47	5
34150	14	48	—
34293	8	38	0.1
34505	1	29	7
34505	15	18	7
34637	1	3	12
35149	1	22	210
35150	1	23	6
35955	7	25	1.4
35956	7	27	2.4
35960	3	26	0.4
35963	3	22	1.2
35971	1	33	1.4
35972	1	31	12
35989	7	28	4
36174	4	24	2
36175	4	28	0.1
36518	3	8	—
37372	6	19	13
37668	16	51	4.25
37697	16	60	—
60076	14	33	—
77432	12	31	0.3
80503	16	13	0.2
90320	6	13	3.05
90321	6	12	10
93323	14	1	15
93382	14	32	14
93383	14	31	3
93864	4	47	0.05
94564	10	3	9
95150	14	53	—
99030	18	16	—
99031	18	17	—
99057	18	2	—
99058	18	3	—
99059	18	4-2	—
99060	18	4-1	—
99061	18	7	—
99062	18	10	—
99063	18	13	—
99064	18	18	—
99065	18	20	—
99066	18	21	—
99067	18	23	—
99068	18	24	—
99069	18	25	—
99070	18	28-1	—
99071	18	28-2	—
99072	18	1-1	—

Parts No.	Page No.	Ref. No.	Weight (g)
99073	18	1-2	—

-Y4 DA Gauge Parts

YAM 10260 Vinyl Tubing
(Small) Blue

YAM 28107 Stitch Plate
(Y4)

YAM 28109 Presser Foot
(Y4)

YAM 22430 Edge Guide
Complete
(Y4)

YAM 28083 Aux. Feed
Dog (Y4)

YAM 28082 Main Feed
(Y4) Dog

YAM 28081 Diff. Feed
(Y4) Dog

From the library of: Diamondneedle Corp

Ref. No.	Parts No.	Description	品名	Amt. Req.
1	26022	Thread Lead Bar	糸道棒	1
2	3635	Screw for 26022	糸道棒止ネジ	1
3	26301	Top Cover	上カバー	4
4	5083	Screw for 26301	上カバー止ネジ	1
5	916	Brand Name Plate	銘板	1
6	26007	Top Cover Gasket	上カバーパッキン	1
7	32612	Top Cover Packing Piece	上カバー詰栓	1
8	20004	Oil Cap	オイルキャップ	1
9	20005	Oil Cap Seal	オイルキャップリング	1
10	5075	Oil Hole Screw	給油口蓋ネジ	1
11	525	Oil Hole Seal	蓋ネジパッキン	1
12	26023	Thread Lead Bar Holder	糸道棒振れ止メ	1
13	5343	Screw for 26023	糸道棒振れ止メ止ネジ	2
14	26010	Needle Thread Cover Hinge	針糸カバーヒンジ	1
15	1223	Screw for 26010	針糸カバーヒンジ止ネジ	2
16	726	Rivet for 26010, 24188	止メ鉄	3
17	24025	Needle Thread Cover	針糸カバー	1
18	1047	"ZF" Mark	ZFマーク	1
19	24026	Needle Thread Cover Hinge Pin	針糸カバーヒンジピン	1
20	396	Stop Rubber for 22371	ゴム座	1
21	22371	Needle Thread Cover Stop Spring	針糸カバー圧着バネ	1
22	24159	Safety Platch Spring	アイガードヒンジバネ	1
23	7006	Screw for 24159	アイガードヒンジバネ止ネジ	1
24	24028	Safety Plate	アイガード	1
25	24082	Safety Plate Hinge Pin	アイガードヒンジピン	1
26	1459	Screw for 24082	アイガードヒンジピン止ネジ	1
27	22259	Needle Thread Cover Latch Pin Stopper	針糸カバーフックピン受け座	1
28	24188	Needle Bar Connecting Link Cover (Right)	針棒カバー(右)	1
29	24011	Needle Bar Connecting Link Cover (Rear)	針棒カバー(後)	1
30	5000	Screw for 24011, 28044	止ネジ	4
31	26004	Side Cover	側面カバー	1
32	4445	Screw for 26004	側面カバー止ネジ	4
33	22261	Needle Thread Cover Latch Pin Spring	針糸カバーフックピンバネ	1
34	22764	Needle Thread Cover Latch Pin	針糸カバーフックピン	1
35	1228	Screw for 22764, 33081	止ネジ	2
36	26015	Machine Frame Bracket	フレームブラケット	1
37	9853	Screw for 26015	フレームブラケット止ネジ	2
38	26016	Fabric Guide	布案内	1
39	1331	Screw for 26016	布案内止ネジ	2

*Ref. No. 40 to 61 See the following page.

From the library of: Diamond Needle Corp

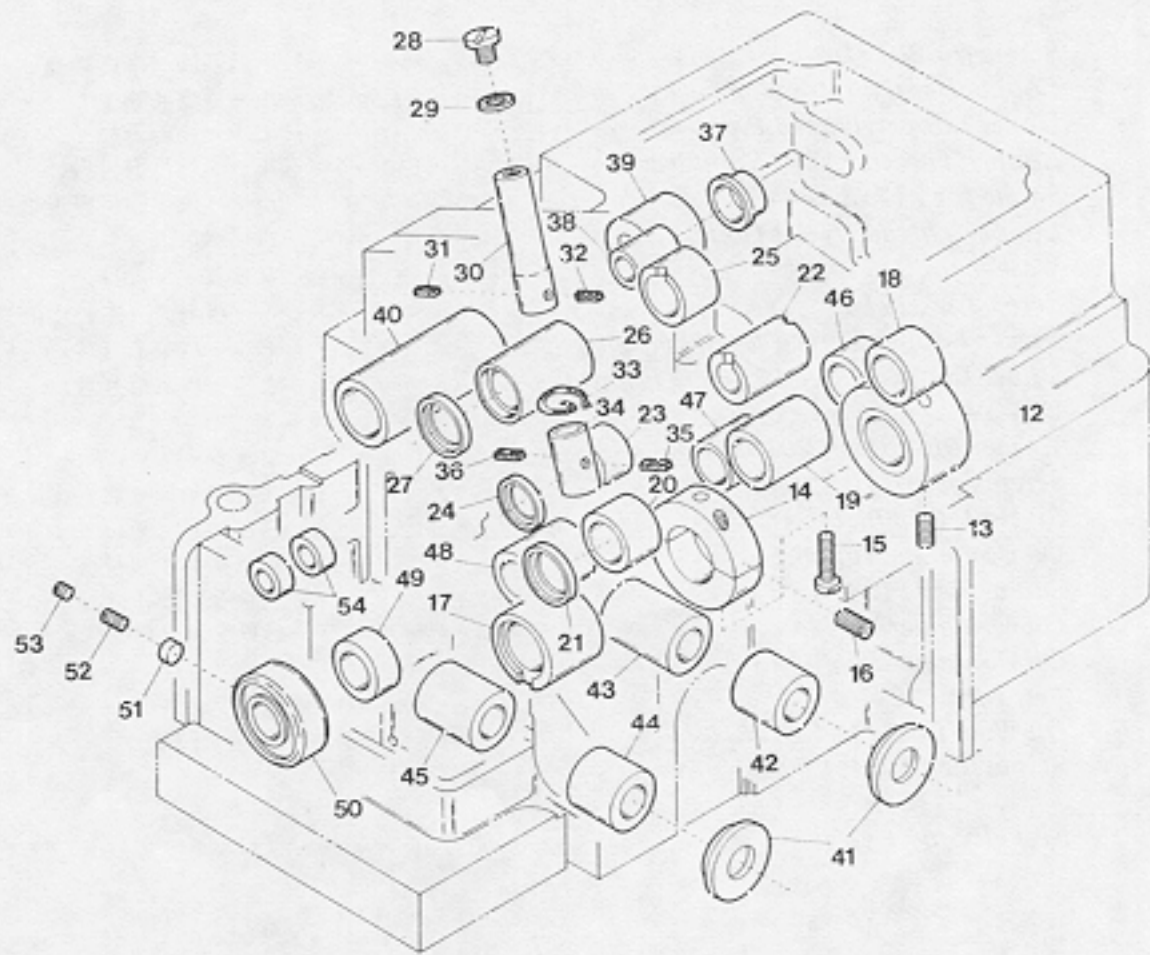
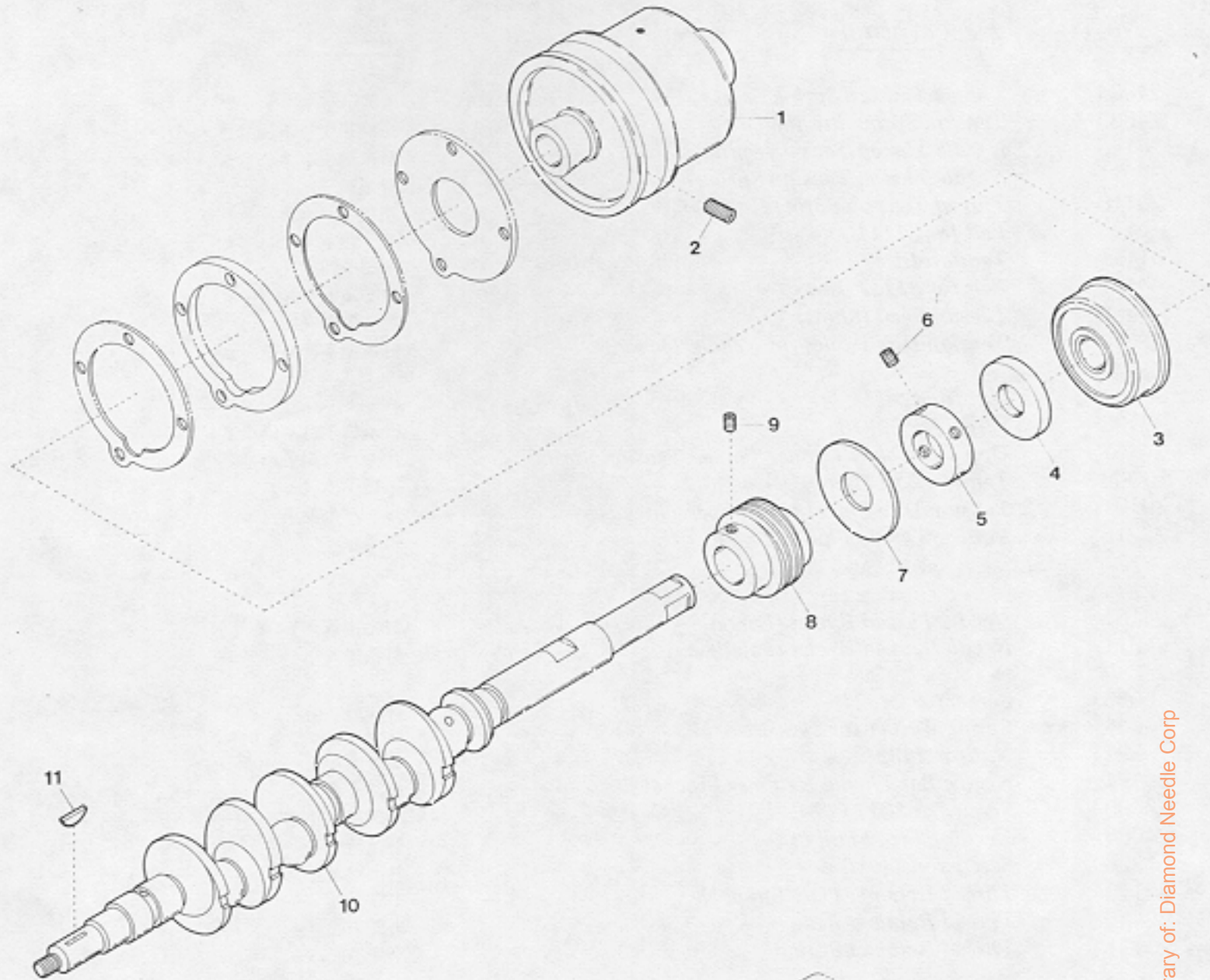

Ref. No.	Parts No.	Description	品名	Amt. Req.
1	24051	Pulley	プーリ	1
2	4123	Screw for 24051	プーリ止ネジ	2
3	20154	Crankshaft Ball Bearing (Large)	ボールベアリング (大)	1
4	26420	Crankshaft Ball Bearing Retaining Washer	ベアリング位置決めリング	1
5	26426	Top Feed Driving Connecting Rod Spacer Collar	上送りロッドスベサカラー	1
6	1459	Screw for 26426	上送りロッドスベサカラー止ネジ	4
7	26403	Top Feed Driving Connecting Rod Spacer	上送りロッドスベサ	1
8	26400	Oil Pump Driving Worm Eccentric	ウォームエキセン	1
9	3638	Screw for 26400	ウォームエキセン止ネジ	2
10	28009	Crankshaft	クランクシャフト	1
11	32780	Feed Driving Eccentric Key	キー	1
12	26419	Crankshaft Bushing (Right)	クランクシャフトブッシュ (右)	1
13	3434	Screw for 26419	クランクシャフトブッシュ (右) 止ネジ	1
14	20157	Crankshaft Bushing (Center)	クランクシャフトブッシュ (中)	1
15	1170	Screw for 20157	クランクシャフトブッシュ (中) 止ネジ	2
16	3654	Screw for 20157	クランクシャフトブッシュ (中) 止ネジ	1
17	28010	Crankshaft Bushing (Left)	クランクシャフトブッシュ (左)	1
18	24053	Upper Knife Driving Shaft Bushing (Right)	上メス軸ブッシュ (右)	1
19	26046	Upper Knife Driving Shaft Bushing (Center)	上メス軸ブッシュ (中)	1
20	26045	Upper Knife Driving Shaft Busing (Left)	上メス軸ブッシュ (左)	1
21	32684	Oil Seal for Upper Knife Driving Shaft	上メス軸オイルシール	1
22	26070	Top Feed Vertical Motion Shaft Bushing (Right)	上送り上下軸ブッシュ (右)	1
23	26069	Top Feed Vertical Motion Shaft Bushing (Left)	上送り上下軸ブッシュ (左)	1
24	26071	Oil Seal for Top Feed Vertical Motion Shaft	上送り上下軸オイルシール	1
25	24014	Needle Bar Driving Shaft Bushing (Right)	針棒クランク軸ブッシュ (右)	1
26	26035	Needle Bar Driving Shaft Bushing (Left)	針棒クランク軸ブッシュ (左)	1
27	26036	Oil Seal for Needle Bar Driving Shafi	針棒クランク軸オイルシール	1
28	3636	Cap Screw for 24016	針棒ブッシュ (上) 蓋ネジ	1
29	526	Seal for 24016	針棒ブッシュ (上) 蓋ネジパッキン	1
30	24016	Needle Bar Bushing (Upper)	針棒ブッシュ (上)	1
31	325	Oil Wick for 24016	油芯	1
32	278	Oil Wick for 24016	油芯	1
33	224	Oil Wick for 26043	油芯	1
34	26043	Needle Bar Bushing (Lower)	針棒ブッシュ (下)	1
35	290	Oil Wick for 26043	油芯	1
36	199	Oil Wick for 26043	油芯	1
37	26067	Presser Foot Lifter Lever Shaft Bushing (Right) End Cap	押エ揚ゲ軸ブッシュ (右) 蓋	1
38	26055	Presser Foot Lifter Lever Shaft Bushing (Right)	押エ揚ゲ軸ブッシュ (右)	1
39	26090	Top Feed Shaft Bushing (Upper) (Right)	上送り軸ブッシュ (上) (右)	1
40	26089	Top Feed Shaft Bushing (Upper) (Left)	上送り軸ブッシュ (上) (左)	1
41	20334	Looper Driving Shaft Oil Seal	ルーバ軸オイルシール	2
42	24054	Upper Looper Driving Shaft Bushing (Front)	上ルーバ軸ブッシュ (前)	1
43	24055	Upper Looper Driving Shaft Bushing (Rear)	上ルーバ軸ブッシュ (後)	1
44	24056	Lower Looper Driving Shaft Bushing (Front)	下ルーバ軸ブッシュ (前)	1
45	24057	Lower Looper Driving Shaft Bushing (Rear)	下ルーバ軸ブッシュ (後)	1
46	24058	Feed Bar Driving Shaft Bushing	送り軸ブッシュ	2
47	26407	Top Feed Shaft Bushing (Lower)	上送り軸ブッシュ (下)	1
48	28012	Feed Bar Driving Shaft Bushing (Second from Right)	送り軸ブッシュ (右中)	1
49	28013	Feed Bar Driving Shaft Bushing (Second from Left)	送り軸ブッシュ (左中)	1
50	28014	Feed Bar Driving Shaft Ball Bearing	ボールベアリング	1
51	926	Rubber Seat for 28014	ゴム座	1
52	2022	Screw for 28014	ボールベアリング止ネジ	1
53	7645	Screw for 28014	ボールベアリング止ネジ	1
54	28038	Differential Feed Control Lever Shaft Bushing	送り調節レバー軸ブッシュ	2

From the library of: Diamond Needle Corp

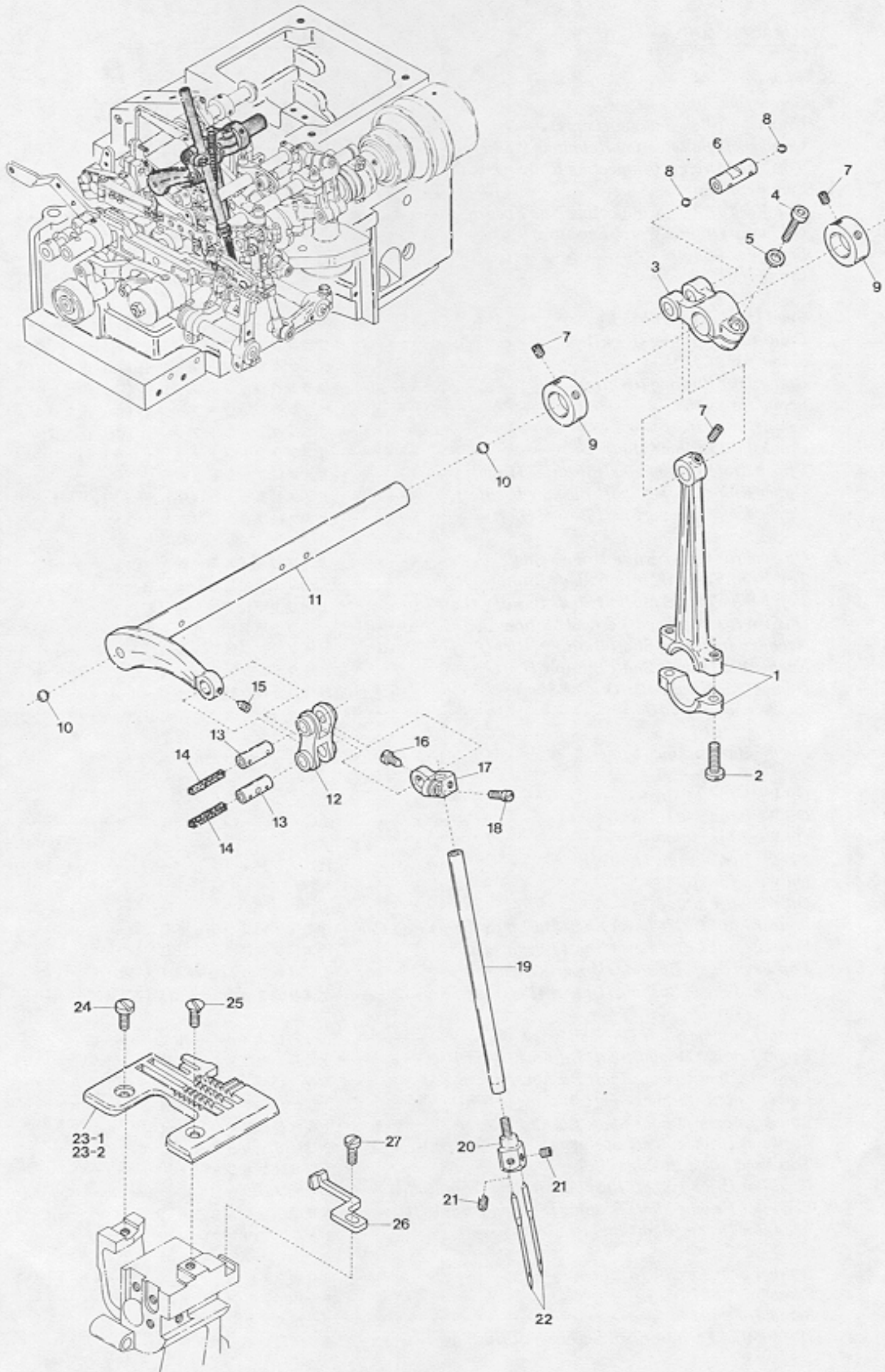

From the library of: Diamond Needle Corp

<u>Ref. No.</u>	<u>Parts No.</u>	<u>Description</u>	<u>品名</u>	<u>Amt. Req.</u>
1	24004	Needle Bar Driving Connecting Rod	針棒クランクロッド	1
2	5070	Screw for 24004	針棒クランクロッド止ネジ	2
3	24005	Needle Bar Driving Lever	針棒クランク軸腕	1
4	5520	Screw for 24005	針棒クランク軸腕止ネジ	1
5	520	Washer for 24005	ワッシャ	1
6	24094	Needle Bar Driving Connecting Rod Pin	針棒クランクロッドピン	1
7	3638	Screw for 24094, 32646, 24168	止ネジ	6
8	637	Seal Plug for 24094	詰栓	2
9	32646	Needle Bar Driving Shaft Collar	針棒クランク軸カラー	2
10	639	Seal Plug for 26042	詰栓	2
11	26042	Needle Bar Driving Shaft	針棒クランク軸	1
12	90321	Needle Bar Connecting Link	針棒リンク	1
13	90320	Needle Bar Connecting Link Pin	針棒リンクピン	2
14	278	Oil Wick for 90320	油芯	2
15	3313	Screw for 90320	針棒リンクピン止ネジ	1
16	4313	Screw for 90320	針棒リンクピン止ネジ	1
17	24008	Needle Bar Connecting Bracket	針棒抱キ	1
18	1186	Screw for 24008	針棒抱キ止ネジ	1
19	37372	Needle Bar	針棒	1
20	24132	Needle Clamp	針止メ	1
21	3637	Screw for Needle	針止ネジ	2
22	—	Needle (System : DCx1)	針	2
23-1	28080	Stitch Plate (Y5)	針板 (Y5)	1
23-2	28088	Stitch Plate (Y6)	" (Y6)	1
24	4406	Screw for Stitch Plate	針板止ネジ	1
25	5401	Screw for Stitch Plate	針板止ネジ	1
26	28084	Needle Guard (Front)	針受ケ (前)	1
27	4404	Screw for 28084	針受ケ (前) 止ネジ	1



From the library of: Diamond Needle Corp

18